

Tewksbury Lecture: Control and application of environment-sensitive fracture processes

A. R. C. WESTWOOD

Martin Marietta Laboratories, Baltimore, Maryland, USA

This paper is concerned with the possibility of influencing the effects of chemically active environments on fracture processes in some controlled and predictable manner, such that their potentially detrimental effects on mechanical reliability are minimized, and their ability to facilitate fracture is utilized when this is desirable, as in materials removal processes. Phenomena such as stress-corrosion cracking, liquid metal embrittlement and chemomechanical effects are considered as they relate to the fracture behaviour of metals, ceramics, minerals, rocks, glasses, organic crystals and polymers.

1. Introduction

The year 1974 is a most appropriate year in which to focus attention on the environment-sensitive aspects of fracture behaviour, for it is exactly one hundred years ago that the first record of such behaviour appeared in the scientific literature. This was in 1874, when Reynolds [1] associated certain detrimental effects on the ductility of iron with the presence

of occluded hydrogen. Unfortunately, the phenomenon of hydrogen embrittlement is still with us, as pernicious as ever [2]. The year 1974 is also the fiftieth anniversary of the publication of the celebrated paper by Joffe *et al.* [3], in which it was proposed that the significant enhancement in ductility of salt crystals when deformed in a solvent environment (Fig. 1a) [4], is a consequence of the removal by dissolution of

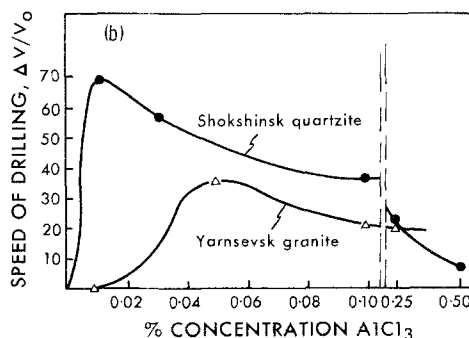
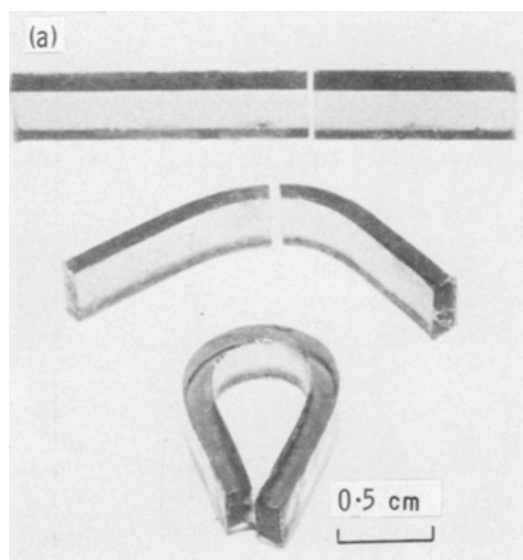

Figure 1 (a) Illustrating Joffe's effect with irradiated KCl crystals. Upper crystal deformed in air; middle crystal immersed in water for 60 sec, dried and deformed in air; lower crystal deformed under water [4]. (b) Illustrating increased speed of drilling of quartzite as function of $AlCl_3$ concentration in water [5].

This paper is the text of the Third Tewksbury Lecture on Fracture, delivered 4 June 1974, at the University of Melbourne, Australia.

pre-existing surface cracks. And thirty years ago, Rebinder and his colleagues published the book entitled "Hardness Reducers in Rock Drilling" [5], describing their finding that surface active environments can markedly and beneficially influence the rates of penetration of bits through hard rocks (Fig. 1b).

Today, materials scientists and engineers are very much aware of the fact that chemical environments can significantly influence the reliability of structural materials in service, and that their influence usually is detrimental. Such recognition is evidenced by the increasing use in design studies of fracture mechanics data developed using pre-cracked specimens exposed to some appropriate test environment, e.g. a chloride solution.

Examples of environment-sensitive fracture behaviour abound in the scientific and engineering literature. A few of these, chosen to illustrate the generality and diversity of such effects, include:

(i) the catastrophic embrittlement by nitrogen tetroxide of the Ti-6Al-4V oxidizer tank for the Apollo booster (Fig. 2a) [6] – an example of stress corrosion cracking;

(ii) the failure by cleavage of a notched aluminium monocrystal stressed in liquid gallium (Fig. 2b) [7] – an example of liquid-metal embrittlement (LME);

(iii) the formation of cracks at the intersections of slip bands and a grain boundary in AgCl lightly strained in 6N aq. NaCl (Fig. 2c) [8]. Such cracks propagate rapidly along the boundary, sometimes producing brittle failure in this otherwise ductile material at stresses below its macroscopic flow stress – an example of "complex-ion embrittlement";

(iv) the 90% reduction in ductility of naphthalene crystals on immersion in benzene [9];

(v) the ten-fold reduction in stress required to propagate a crack in polymethylmethacrylate (PMMA) when exposed to methyl alcohol instead of air [10];

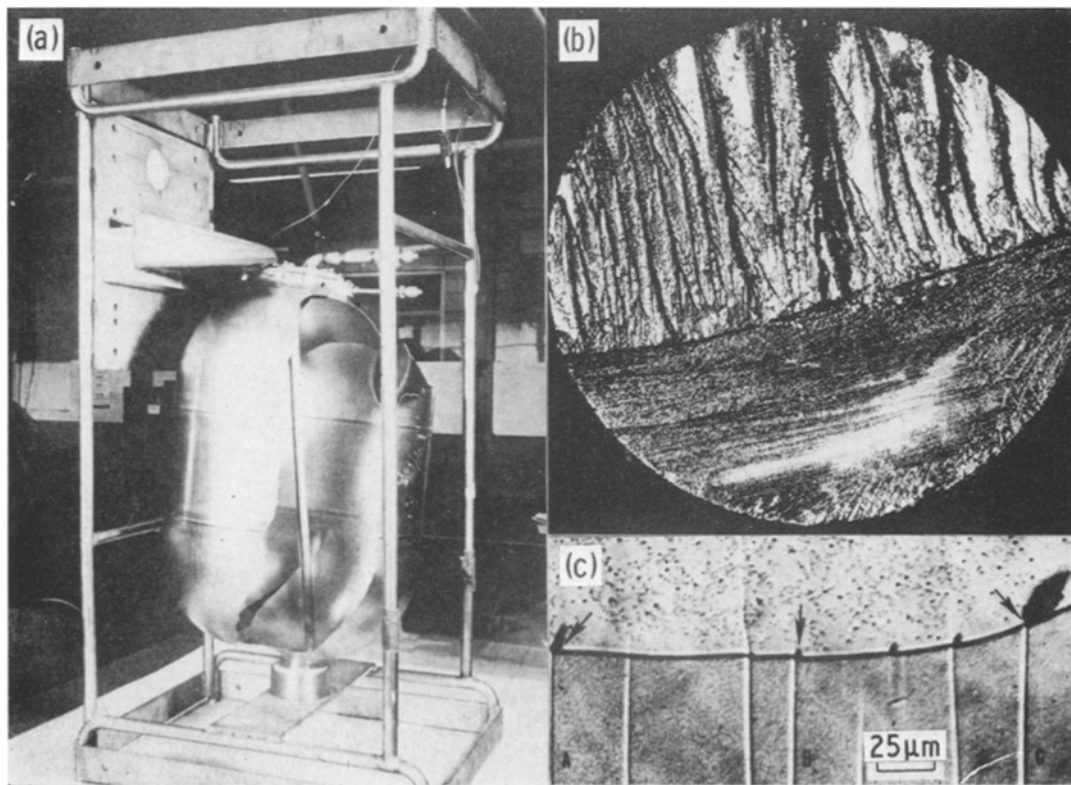

Figure 2 (a) Failure by SCC of a Ti-6Al-4V oxidizer tank for the Apollo booster [6]. (b) Cleavage failure of a notched, 12 mm diameter aluminium monocrystal stressed in liquid gallium. Fracture surface is predominantly $\{100\}$ [7]. (c) Polycrystalline AgCl strained in aq. 6N NaCl containing AgCl_4^{3-} complexes. Cracks formed at intersections of slip lines (A-C) and grain boundary, e.g. at arrows.

(vi) the thousand-fold increase in crack propagation velocity at a given stress intensity in soda-lime glass when exposed to water instead of dry nitrogen [11].

Many more examples of such behaviour can be presented. However, the purpose of this paper is *not* to provide a review of such deleterious effects, nor even to bring news of fresh disasters. Rather, it is to consider the possibility of influencing the effects of chemical environments on fracture processes in some controlled and predictable manner such that (i) their potentially detrimental effects on mechanical reliability are minimized, and (ii) their ability to facilitate fracture is utilized when this is desirable, as in the machining, drilling and comminution of solids. Accordingly, this paper will be less concerned with the finer points of the mechanisms of the phenomena of interest than with making use of what understanding or empirical relationships exist to control or apply environmental effects. For convenience, the examples chosen for discussion have been selected where possible from work undertaken by the author and his colleagues.

2. Environment-sensitive fracture processes (ESFP) in metals

2.1. Liquid metal environments

Embrittlement of a solid metal by an active liquid metal is generally considered to result from some chemisorption-induced reduction in the cohesive strength of atomic bonds at regions of stress concentration in the solid metal. Thus, the prerequisites for its occurrence are (i) a tensile stress, (ii) either a pre-existing crack, or some measure of plastic deformation and the presence of a stable obstacle to dislocation motion in the lattice, e.g. a grain boundary or precipitate particle, and (iii) adsorption of the active embrittling species specifically at this obstacle and subsequently at the tip of any propagating crack [12]*.

The factors that determine which liquid metal will actually embrittle which solid metal remain unclear. In general, however, it appears that to constitute an embrittlement couple, both the solid metal and the liquid metal should exhibit limited mutual solubility and little tendency to form stable, high melting point compounds [14, 15]. The latter requirement suggests two possible ways of inhibiting LME:

(i) by addition of a soluble element B* to the

liquid metal B which embrittles solid metal A; B* being chosen because of its known tendency to form stable compounds with A. Inhibition may then result either from preferential adsorption of B* on A, screening A from B, or from the formation of relatively strong A-B*-A bonds at crack tips which counter the weakening influence of the element B on A-A bonds.

Several examples of the usefulness of this approach may be cited. For instance, barium is slightly soluble in liquid mercury at room temperature, and is known to form stable intermetallic compounds with zinc, such as Zn₁₃Ba [16]. Thus, the addition of a small amount of barium to mercury might be expected to reduce the severe embrittlement of zinc by mercury, and such an effect has been observed [17]. The fracture stress of polycrystalline zinc specimens (~ 1 mm grain diameter) amalgamated with pure mercury was determined to be $\sim 6 \pm 1.5 \text{ MN m}^{-2}$, whereas that of similar specimens coated with mercury containing 0.4 at. % barium was $10 \pm 3.2 \text{ MN m}^{-2}$ – about a 70% improvement. Similarly, the embrittlement of polycrystalline copper by bismuth is well known. But, according to recent work by Yuschenko [18], additions to bismuth of tin (which forms intermetallic compounds with copper [16]) markedly reduces the severity of embrittlement. Other examples include the addition of indium to reduce the mercury embrittlement of silver and α -brass [19].

(ii) by alloying a soluble element A* with the solid metal A; A* being chosen because of its known tendencies to form strong intermetallic bonds with the embrittling liquid metal element. A possible example of such behaviour is the addition of ~ 30 at. % of gold to silver, which effectively inhibits the embrittlement of silver by gallium, but not by mercury [20]. Gold forms high melting point intermetallic compounds with gallium, but not with mercury [16].

Another way of controlling the severity of LME is by changing the operating temperature, for LME is extremely temperature sensitive, as illustrated in Fig. 3a [19]. Thus (see Fig. 3b), by heat-treating a leaded 4145 steel above 750 K, the cracking associated with the combined action of thermal and mechanical stresses and molten lead at the grain boundaries which occurs during treatment at temperatures between 650 and 750 K can be avoided [21].

Next consider the possibility of utilizing the

*For a more complete review of the characteristics and mechanisms of LME, see [13].

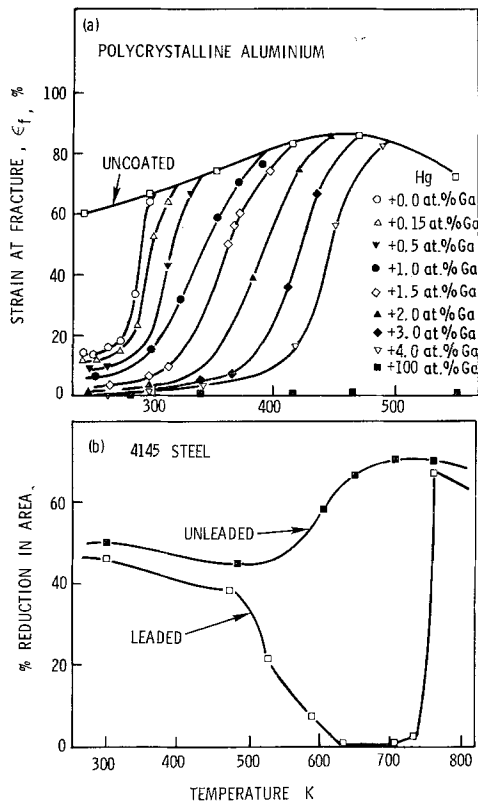

Figure 3 (a) Illustrating temperature dependence of LME for polycrystalline aluminium strained in mercury, gallium and Hg-Ga solutions [19]. (b) Variation of reduction in area with temperature for leaded and unlead 4145 steels [21].

remarkable effects of specific liquid metal environments on the fracture behaviour of given solid metals to some more desirable end, for example, comminution or drilling. Some work by Shchukin *et al.* [22] indicates the potential of this approach. Fig. 4 shows that the rate of bit penetration through a stainless steel can be increased eight-fold by drilling under a tin-zinc eutectic environment at 470 K, and two- to three-fold in an indium-gallium-tin eutectic at 290 K over that in air.* Apparently, duralumin can be drilled sixty times faster in the latter eutectic at 290 K than in air, and the machining of copper also is facilitated. Likewise, while it is extremely difficult to pulverize a ductile metal such as zinc in a conventional vibratory ball mill, the presence of 1% of gallium leads to increases in pulverization rate of more than twenty-fold [23]. Similar effects on pulverization

*Oleic acid also is reported to accelerate drilling by comparable amounts [22].

behaviour have been observed also for tin, cadmium, aluminium and bismuth.

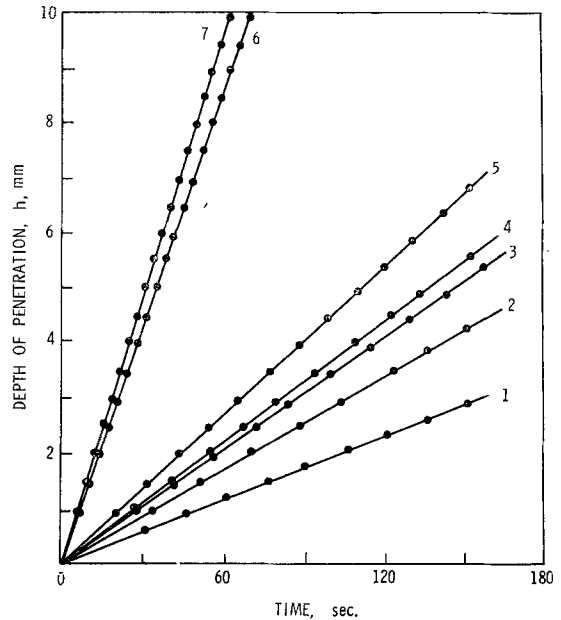

Figure 4 Penetration as function of time for drilling a stainless steel (1) dry, and in the following molten metals: (2) tin, (3) gallium, (4) indium, (5) In-Ga-Sn eutectic, (6) Sn-Pb eutectic, (7) Sn-Zn eutectic [22].

No systematic work appears to have yet been done on such applications. But, if reliable ways can be found for removing the embrittling liquid metal species from the work piece following the cutting operation, such an approach might be well worth pursuing, especially for some of the otherwise hard to machine metals such as nickel or titanium-base alloys.

2.2. Electrolytes

Without question, the most important influences of electrolytes on fracture processes in metals are associated with the phenomena of *stress-corrosion cracking (SCC)* and *hydrogen embrittlement*. Numerous attempts to control or eliminate these two detrimental effects have been, and are being undertaken, and only a few of the approaches adopted are cited here.

Clearly, the best solution to the SCC or hydrogen embrittlement problem is to avoid using a metal or alloy susceptible to embrittlement by the particular working environment

whenever possible. Obvious though this solution is, designers still give too little attention to the choice of appropriate materials. For example, the high strength aluminium alloy 7079-T6* should never be used when even the slightest likelihood of a stress corrosion problem exists [24]. This material is so susceptible to SCC that failures often occur within a year of exposure to a normal industrial atmosphere under stresses as low as 15% of the yield stress. It has been estimated that following this one recommendation alone could save millions of dollars yearly by minimizing the downtime to replace cracked parts made from 7079-T6. Thus, part of the solution to the stress corrosion problem involves developing an awareness on the part of the design engineer of the large amount of useful information already available on the behaviour of numerous alloys in many environments. The volume edited by Brown [25] is an excellent source of such information, containing data on the SCC behaviour of aluminium and titanium alloys, and high strength steels.

A second approach to minimizing the impact of SCC is via intelligent design, avoiding for example assembly or quenched-in stresses,

especially across sections where the grain structure renders the material most susceptible to penetration by the environment. The short transverse direction in highly textured aluminium alloys is particularly susceptible, for instance. The design approach may also be useful in combating hydrogen embrittlement in high strength steels and titanium alloys. The mechanism of hydrogen embrittlement itself remains unclear, and one of its complexities is the need to explain how such a small bulk concentration can induce such catastrophic results. Current opinion appears to be that the application of a tensile load to a precracked specimen leads to a hydrostatic stress component ahead of the crack tip. This, in turn, gives rise to a locally increased equilibrium hydrogen solubility, providing the driving force for hydrogen diffusion to, and consequent embrittlement of, the crack tip region. The application of a torsional load, on the other hand, does not introduce any such hydrostatic component to redistribute the hydrogen. In accord with this hypothesis, Fig. 5 shows that a Ti-8Al-1Mo-1V alloy is essentially immune to hydrogen embrittlement when tested

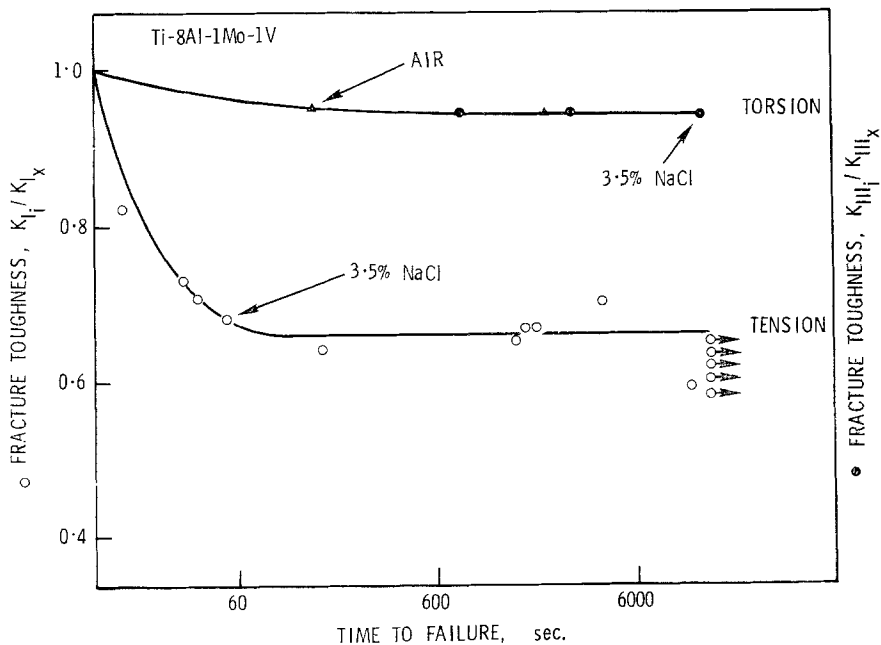

Figure 5 Comparison of susceptibility to SCC of Ti-8Al-1Mo-1V exposed to air and 3.5% NaCl under cantilever beam (tension) and torsional loading [26]. K_{II} and K_{IX} are, respectively, the fracture toughness in air and 3.5% NaCl under mode I loading. K_{III} and K_{IIIx} have the same connotation for mode III loading.

*Al7079 contains 3.8 to 4.8 Zn, 2.9 to 3.7 Mg, 0.4 to 0.8 Cu, 0.4 Fe, 0.3 Si, 0.1 to 0.3 Mn, 0.1 to 0.25 Cr, 0.1 Ti and 0.15 other elements. The T6 condition is solution heat-treated and artificially aged.

in torsion in 3.5% aqueous NaCl, but quite susceptible when tested in tension [26].

It may be questioned, of course, whether the corrosive environment can readily penetrate to a crack tip under torsional loading. However, in answer to this point, it has been demonstrated [27] that failure does occur in the α -brass aq. ammonia system when the specimens are loaded in torsion, so that presumably access to the crack tip is not a critical issue.

Accepting the above result, then, the message to the designer facing a potential hydrogen embrittlement problem is to attempt to load the structure in torsion rather than tension whenever practical. He should also consider the use of material in thin sheet form, so that it is stressed under plane stress rather than plane strain conditions. The latter consideration leads to the possibility of developing versatile sheet composite materials, in which crack blunting at each interface prevents large stress concentrations from developing in otherwise SC-sensitive materials [28]. This approach deserves further research effort.

Another approach for minimizing susceptibility to SCC is via the application of protective coatings or various types of corrosion inhibitor. Often the surface is subjected to shot peening prior to coating, which effectively obliterates the grain structure, and places the surface layers in compression (Fig. 6) [29]. Such treatment is of limited value, however, if the alloy is also susceptible to pitting corrosion. Control of SCC by modifying the composition of the liquid environment through the use of inhibitors has been attempted for many years. Of course, such an approach is usually limited to closed systems, where there is no need to continually replenish the inhibitor. Only rarely, however, has the choice of inhibitor been based on any supposed understanding of the mechanism of failure involved. Moreover, a fundamental problem in inhibiting the propagation of stress corrosion cracks in high strength steels, aluminium alloys and titanium alloys is the fact that the crack tip "cell" chemistry is acidic, and most inhibitors are ineffective in acid solutions, especially if chloride ions are also present [30]. This is an area which deserves more research attention.

Since SCC in aluminium alloys is almost always intercrystalline, much attention has been devoted to the possibility of controlling this problem by changing the microstructure of the alloy in the vicinity of the grain boundary. In

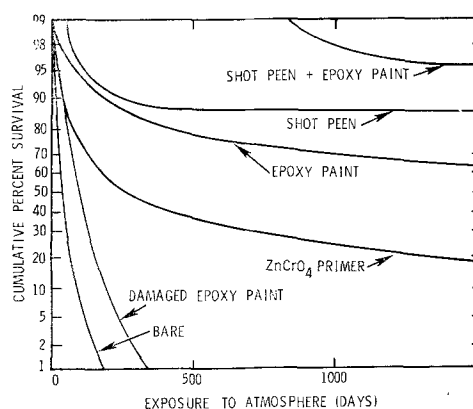

Figure 6 Protection of 2014-T651 and 7079-T651 aluminium alloys against SCC in industrial atmospheres by various treatments [29].

the high strength Al-Zn-Mg alloys, for example, crack propagation is considered to occur by preferential anodic dissolution of the material in the vicinity of the grain boundary. Following age hardening, this region is characterized by a distribution of relatively coarse $MgZn_2$ precipitates along the boundary plane, and an adjacent precipitate free zone (Fig. 7) [31]. When such alloys are exposed to aqueous chloride environments, hydrolysis reactions cause the solution at the tip of a propagating crack to adopt a pH \sim 3.5, essentially independent of the pH of the bulk test environment [32]. Under such conditions, the $MgZn_2$ particles dissolve very rapidly, and so the time to failure effectively is controlled by the rate at which the crack propagates through the "bridges" of aluminium solid solution separating the particles. It follows, then, that the further apart are the $MgZn_2$ particles, the greater the time to failure. An increase in inter-particle spacing can be achieved by air cooling the alloy from the solution treatment or ageing temperature instead of water quenching, and as much as twenty-fold improvements in times to failure have been produced in this manner [33].

Another approach is via control of the chemical composition of the alloy, and some interesting work on titanium alloys along this line has been undertaken at the Boeing Company [34]. Titanium alloys which contain relatively high aluminium or oxygen contents are very susceptible to SCC in aqueous chloride environments, and the view is emerging that transgranular failure occurs only in alloys exhibiting

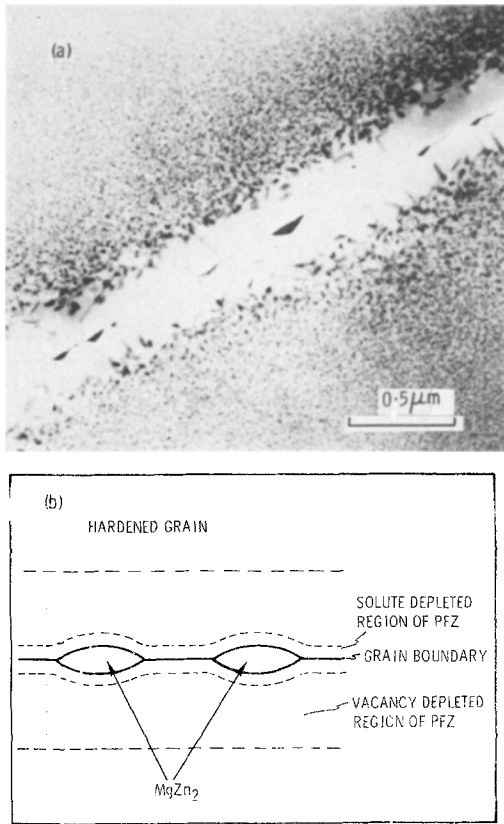

Figure 7 (a) Electron micrograph of grain boundary microstructure of Al-5Zn-2.5Mg following ageing at 450 K for 2.5 h. (b) Schematic diagram of above microstructure [31].

a reduced propensity for cross slip. Since it is known that the transition between cellular and co-planar dislocation arrangements in Ti-Al alloys occurs at $\sim 5\%$ [35], aluminium was held to $< 5\%$ (oxygen is normally controlled to $< 0.3\%$ for similar reasons). Since molybdenum and vanadium were known to be beneficial to SCC resistance, these too were added. Also, additions of β -eutectoid forming elements, such as manganese, were made to provide strength. Some of the test data from these proprietary alloys are shown in Fig. 8, and it is seen that considerable improvements were achieved.

The significant effects of electrolytes on fracture processes can also be used to influence the rate and efficiency of metal removal operations. Research along these lines has led to the development of a new approach to metal cutting, termed electromechanical machining (EMM) [36], in which the workpiece is made an electrode.

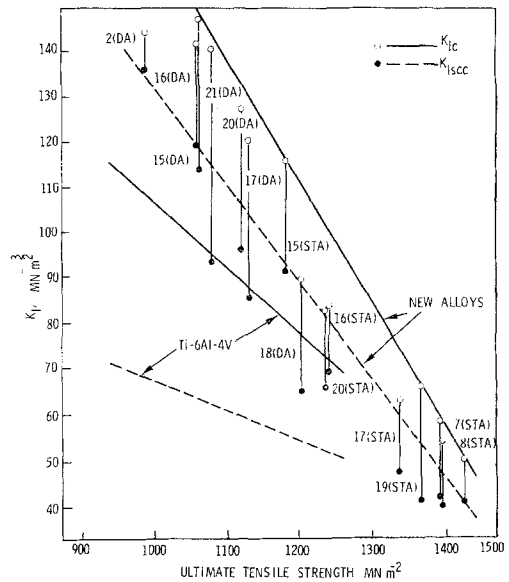

Figure 8 Fracture toughness of experimental Boeing alloys in air and 3.5% NaCl [34].

In conventional metal machining operations, the removal of material is dependent primarily on the coefficient of friction between the tool and the workpiece, and the hardness and work hardening characteristics of the workpiece. Significantly, both the frictional and the mechanical behaviour of metals are affected by electrolytes, their specific behaviour being related to the magnitude of the electrical charge double layer, the evolution of gases, and the presence or absence of oxide films at the surface of the metal. The double layer consists essentially of an excess or deficiency of electrons at the metal surface and an adsorbed layer of solvated ions of opposite charge to that on the metal. These solvated ions are compressible, have finite dimensions and, in effect, act as a lubricating layer. The density of the charge on the surface can be altered and the sign even reversed by application of an external potential and, as one might expect, the coefficient of friction is greatest when the metal surface is uncharged [37].

The variation in flow behaviour of metals in electrolytes as a function of applied potential has been studied by a number of workers [38-42]. And, by way of illustration, it has been shown that varying the potential of a nickel electrode in a 1 N H₂SO₄ electrolyte can change the condition of its surface from one which is covered with a passive (oxide) film to one which is being slowly

dissolved (active dissolution) to one at which hydrogen ions are being discharged [42]. A thin passive film on the surface increases strength and reduces the ductility of the electrode. Slow but continuous dissolution during deformation has just the opposite effect [41]. Cathodically produced hydrogen increases the rate of work hardening, but can also induce catastrophic intergranular embrittlement [43]. In short, electrolytes can exert non-trivial effects on the bulk mechanical properties of metal electrodes.

To examine the influence of such effects in machining, a 7 in. shaper was modified to allow a polycrystalline nickel or superalloy workpiece to be totally submerged in an electrolyte [36]. Cutting speeds ranging from 14 to 50 ft min⁻¹,

depths of cut from 0.003 to 0.03 in., and feeds from 0.003 to 0.01 in. were used. Some results are shown in Fig. 9. Fig. 9a presents the polarization curve for nickel in H₂SO₄, and indicates the areas of passivation, dissolution, etc. Fig. 9b shows how tool deflection (a measure of the force required to remove material and usually inversely related to tool wear) varies with applied potential under otherwise identical cutting conditions. Note that at +1600 mV the work required to remove a given amount of metal is less than when a commercial cutting oil is used. More important than this factor, however, is surface finish, since notches or deep gouges produced during machining can markedly reduce the reliability of a component in service.

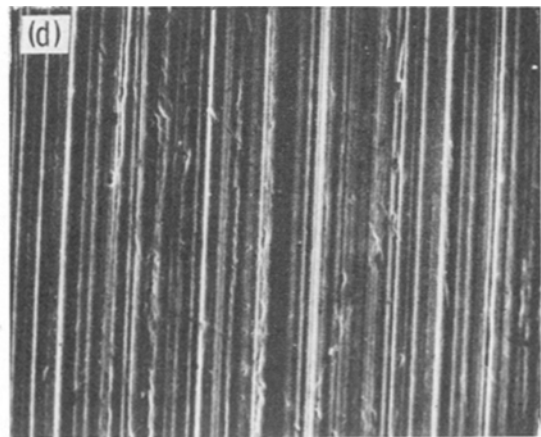
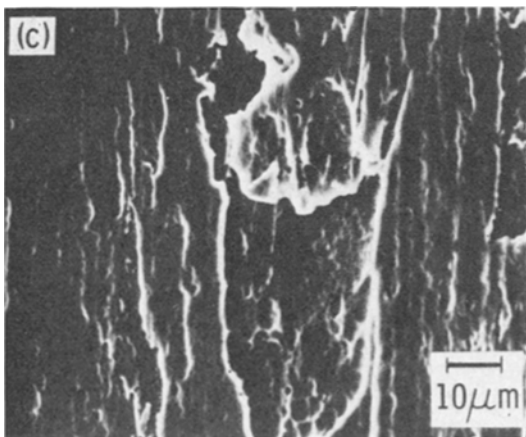
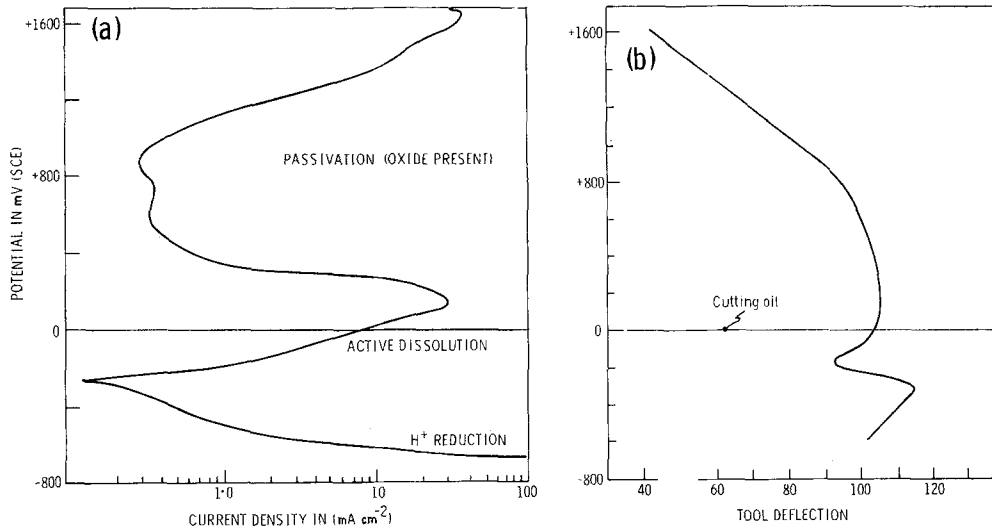

Figure 9 (a) Polarization curve for nickel monocrystal in 1N H₂SO₄. (b) Tool deflection as function of applied potential for machining nickel in a 1N H₂SO₄ electrolyte. (c) SEM of surface produced with no applied potential. (d) Surface produced at +1600 mV potential [36].

This work showed that at the rest potential (i.e. no applied potential), the surface was severely damaged, evidence for seizing and galling being readily apparent (Fig. 9c). As the potential was made more positive, however, a steady improvement in surface quality resulted, and at + 1600 mV – a potential at which oxygen is being evolved from an oxide coated surface – the surface quality was excellent, as is evident from Fig. 9d.

Subsequent studies have shown that electro-mechanical effects can also facilitate drilling [44]. For example, a carbide spade bit was first used to drill two reference holes into a polycrystalline nickel workpiece immersed in a 1 N Na_2SO_4 electrolyte, Fig. 10a. One hole (A) was drilled at an electrode potential of + 1800 mV which, from the data of Fig. 9b, was expected to facilitate cutting. The other hole (B) was drilled at – 600 mV which, for the same reason, was expected to produce slower cutting. As can be seen, the results were as expected. Following initial penetration, cutting at + 1800 mV was twice as fast as at – 600 mV. The effects of switching from one potential to the other as the drill penetrates the electrode are shown in curve C, illustrating clearly the predictable and reversible influences of applied potential. Preliminary drilling results with CG27, a nickel-base superalloy, indicate behaviour similar to that of nickel.

Studies with tempered 4140 steel indicate that the drilling behaviour of this material also is amenable to electromechanical control, but over a different range of potentials to nickel and nickel-base superalloys. Nickel-base materials are difficult to machine because they are characteristically “gummy”, and work harden rapidly. Intuitively, therefore, one would expect that machining behaviour would be improved if the effect of the electrolyte was to harden the surface of the workpiece – which an oxide film would do. Conversely, one might anticipate that the best cutting potential for a hardened 4140 steel would be one at which the electrolyte softened the surface. This would be expected to occur in the active dissolution region, and this is exactly what is observed (Fig. 10b). Potentials in both the hydrogen discharge (– 1100 mV) and passive (+ 800 mV) ranges are quite ineffective, and rapid bit wear occurs. Much enhanced cutting rates and superior tool life occur when drilling is performed in the active dissolution range (– 400 to – 600 mV).

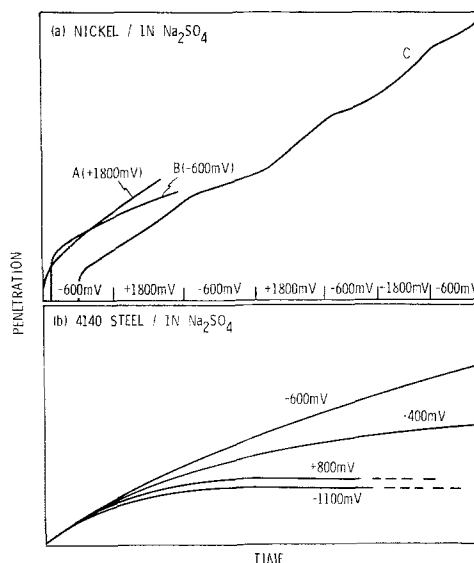

Figure 10 Carbide spade bit drilling of (a) polycrystalline nickel, (b) tempered 4140 steel as function of applied voltage in 1N Na_2SO_4 electrolyte [44].

These data illustrate the importance of proper selection of electrolyte and cutting potential for each material of interest, for cutting potentials which are effective for one material, e.g. certain nickel-base alloys, are not suitable for another, e.g. iron-base alloys. However, the availability of numerous Pourbaix diagrams should facilitate the appropriate choice of both electrolytes and applied potentials.

Incidentally, EMM should not be confused with electrochemical machining (ECM) or electrical discharge machining (EDM). In these techniques, metal removal occurs by some means other than through direct contact between the tool and the workpiece. In EDM, sparks are used to remove material from an electrically conducting workpiece in a liquid dielectric; in ECM, metal removal is achieved in an electrolyte primarily by Faradaic dissolution. In EMM, on the other hand, metal removal occurs by direct contact of a tool with an electrochemically polarized workpiece. In other words, metal removal is achieved by conventional means. Thus, in principle, any conventional drill press, lathe or milling machine can be used.

3. ESFP in crystalline non-metals

In contrast to metals, and because of the much lower concentration and mobility of charge

carriers present, the electrical influence of a species chemisorbed at the surface of a non-metal can be felt as much as several microns in from the surface [45, 46] and, therefore, such adsorbates potentially can affect near-surface flow, fracture, and flow-dependent fracture behaviour. The interesting and sometimes technologically important consequences of such effects will now be discussed.

3.1. Silver chloride

It is generally accepted that, for any given material, stress-corrosion cracking occurs only in certain specific environments. Only recently, however, has significant attention begun to be paid to the chemistry of these environments, and to identification of the critical species responsible for failure. Yet, clearly, if the nature of the critical species and its role in the fracture process can be established, then the possibility of being able to devise means of preventing or inhibiting cracking is much improved. This desirable objective has been achieved in the case of the complex-ion embrittlement of AgCl [47].

When polycrystalline AgCl is exposed at room temperature to aqueous environments containing highly charged complex ions, such as 6N aq. NaCl saturated with AgCl in which the predominant complex species is AgCl_4^{3-} , its fracture

mode changes from extremely ductile and transcrystalline to brittle and intercrystalline (Fig. 2c). Both positively and negatively charged complexes can cause brittle behaviour, and failure can be induced at stresses as low as one sixth of the macroscopic flow stress. Of particular interest is the fact that the severity of embrittlement increases with the concentration and charge density of the complex species present in the environment. Such embrittlement is now thought to be associated with the repeated formation and rupture of point-defect hardened charge double layers, as illustrated schematically in Fig. 11, and substantial kinetic, mechanical, and metallographic evidence in support of this view has been developed [48].

Given that severity of embrittlement is related to the charge or charge density on the adsorbing complex ions, however, it then becomes feasible from a survey of the chemical literature to devise effective counter measures [49]. For example, the successive replacement of sodium ions in 6N aq. NaCl solutions by either potassium or cesium ions inhibits embrittlement (Fig. 12) [47] as a consequence of the formation of mixed ions of lower charge and charge density, such as $[\text{Cs}^+(\text{AgCl}_4^{3-})]^{2-}$. The addition of such group III B cations as Zn^{2+} , Cd^{2+} or Hg^{2+} to 6N aq. NaCl solutions also inhibits embrittlement, in

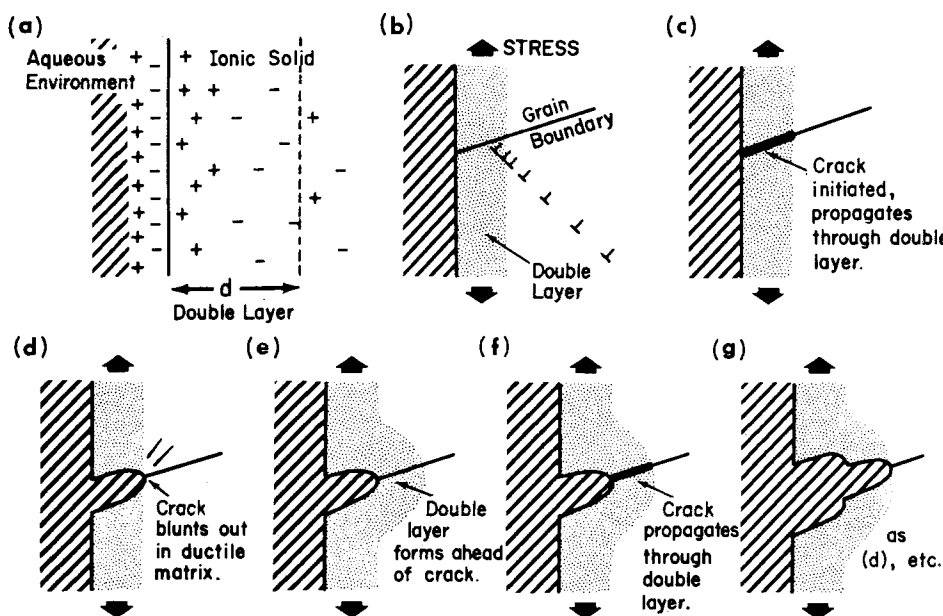

Figure 11 Schematic drawing of the double layer mechanism for the complex-ion embrittlement of AgCl. The charge carriers in the solid are Frenkel defects [48].

this case because the competition of these ions for chloride ions again results in the formation of complexes of charge less than 3-, for example,

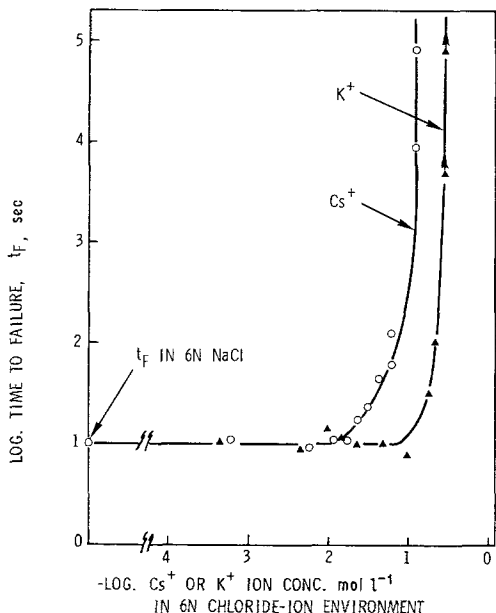
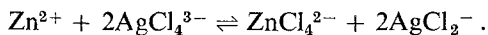

Figure 12 Inhibition of embrittlement of AgCl in 6N NaCl environment by replacement of Na ions by K or Cs ions [47].

3.2. Alkali halide and ceramic materials

There are a number of ways in which chemical environments can influence the fracture behaviour of ionic and ceramic solids. Joffe's [3] original explanation for the large increases in strength (~ twenty-five-fold) and ductility obtained on testing sodium or potassium chloride crystals under water (Fig. 1a), was that this effect was due to the complete elimination, by dissolution, of pre-existing and embrittling surface cracks. It is now evident, however, that several additional phenomena may be involved [50], including (i) the continuous removal of near-surface barriers to dislocation egress, (ii) the removal of embrittling surface films, (iii) the elimination of surface sources of dislocations, and (iv) those effects of solvent environments which reduce the propagatability of cracks, i.e. blunting and healing effects.

Because most ionic-ceramic materials are

notch brittle and do not possess sufficient slip systems to satisfy Von Mises' criterion for inherent ductility, fracture usually occurs as a consequence of some dislocation pile up mechanism after a very limited amount of flow has occurred, with freshly nucleated cracks propagating rapidly to cause catastrophic failure. Thus, the fracture stress of such a solid is determined by, and approximately equal to, its flow stress. An important consequence of this is that the fracture behaviour of most ionic-ceramic solids is quite dependent upon the effects of the environment on their near-surface flow behaviour. Two other important generalizations may also be made at this point; (i) environments which facilitate flow in the near-surface regions of a notch-brittle nonmetallic solid, i.e. soften it, also reduce its fracture strength, and vice versa, and (ii) environments which markedly influence hardness (e.g. dimethylformamide (DMF) for MgO) usually have no significant influence on the energy to propagate cleavage cracks in conventional double cantilever tests, i.e. on the brittle cleavage surface energy of the solid [51]. This implies that the mechanisms by which environment-sensitive fracture occur do not, as proposed by Rebinder [5], primarily involve any adsorption-induced reduction in the

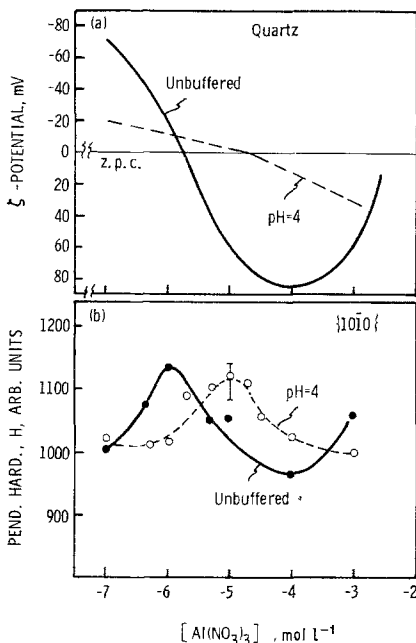

Figure 13 Variation in (a) ζ -potential and (b) pendulum hardness of {10-10} quartz in aq. $\text{Al}(\text{NO}_3)_3$ solutions [59].

surface free energy of the solid. It has been suggested that, instead, such effects are more often associated with environmentally induced variations in flow (dislocation) behaviour, either in the near-surface regions preceding crack initiation or in the vicinity of the crack tip during its sub-critical growth phase. (As mentioned above, no significant effects on fast crack propagation have been observed.) Such effects have, therefore, been termed chemomechanical effects [52] to distinguish them from Rebinder effects which, according to Rebinder [53], by definition are dependent upon adsorption-induced reductions in surface-free energy.

Recent studies have also revealed the existence of a most useful correlation between the environment-sensitive hardness and the ζ -potential* of a non-metallic solid in a liquid environment. This is that hardness, H , is greatest when $\zeta \simeq 0$ [55]. Such a " ζ -correlation", perhaps first noted for AgBr in aqueous bromide and AgI in aqueous iodide environments [56], has now been established for alumina [57], calcite [58] quartz [59] (Fig. 13), magnesium oxide [60], and soda-lime (s.l.) glass [61] in a variety of aqueous and non-aqueous solutions. Thus, it is possible that this correlation is a property generic to inorganic non-metals, both crystalline and non-crystalline.

Now for crystalline solids, hardness is controlled primarily by the mobility of near-surface dislocations. The ζ -correlation implies, therefore that such mobility should be a minimum when $\zeta \simeq 0$. Etch-pitting studies of the movement of edge and screw dislocations around hardness indentations in freshly cleaved MgO surfaces confirm this expectation (Fig. 14a and b) [60].

The explanation for the existence of such a

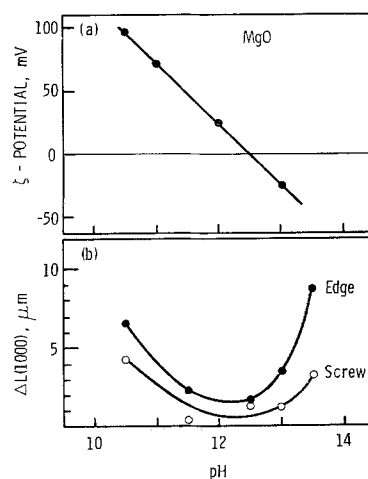

Figure 14 Variation with pH of (a) ζ -potential, and (b) dislocation mobility parameter $\Delta L(1000)$ for MgO in 10^{-2} N aq. NaOH [60]. Note that dislocation mobility is least, i.e. the crystal is hardest, when $\zeta \simeq 0$.

correlation remains obscure at this time, however, because no detailed mechanistic understanding of the influence of environment on near-surface dislocation mobility (or flow behaviour in amorphous materials) yet exists, nor is any clear understanding available of the correlations between ζ -potential, surface-charge, and near-surface electronic structure. Current thinking [60] is that the primary chemisorption event induces a change in the electrostatic potential of the near-surface region of the solid which in turn causes a localized redistribution of the charge carriers (electronic and/or ionic).

For most ionic and covalent crystals, the carriers involved are electrons, and it is envisaged that their redistribution changes both the band structure of the lattice and the electron

*For a comprehensive review of the concept of ζ -potential, and a discussion of the various experimental procedures for determining its value, the reader is referred to the work of Sennett and Oliver [54]. In brief, however, when a non-metallic solid is immersed in an electrolyte it acquires a surface potential, ψ_0 , as a consequence of either (i) the adsorption of specific ions from the environment, or (ii) a change in the concentration or distribution of mobile point defects in the near-surface regions of the solid, or (iii) the establishment of equilibrium between ions making up the surface of the solid and the same constituent ions in solution, the concentrations of which are determined by the solubility product of the solid in the environment. A charge-balancing distribution of counter-ions is then established in the liquid phase, the concentration of the counter-ions decreasing exponentially with distance from the solid surface. Now, under conditions where there is relative motion between the solid and the electrolyte, it is possible to shear off the outer, more diffuse portion of the double layer from the inner, more strongly bound portion. The potential at the plane at which such shearing occurs is defined as the ζ -potential and, in an ideal system, this potential is related in sign and magnitude to ψ_0 , the surface potential. The magnitude of the ζ -potential is strongly influenced by the concentration of the electrolyte and by the valence of the adsorbing ions. Most methods for determining ζ -potential make use of the electrokinetic phenomena resulting from the impression of either a potential gradient or a pressure gradient across the system of interest. For example, small charged particles suspended in a liquid system will move under the influence of an applied potential gradient (electrophoresis), and from a measurement of their velocity and use of an appropriate formula, it is possible to calculate the ζ -potential. Alternatively, if the solid particles are held stationary between two electrodes and the electrolyte is driven through the particulate mass by a pressure gradient, then the (streaming) potential developed across the electrodes can be used to calculate the ζ -potential.

occupation of dislocations and intrinsic and extrinsic point defects in the near-surface region. Consequently, the electrostatic interactions between moving near-surface dislocations, between dislocations and point defects, and between dislocations and the lattice, are changed. And since these are the factors that control dislocation mobility in ionic and covalent materials, the near-surface hardness of such crystals is environment-sensitive.

For s.l. glass, the distribution of mobile non-network ions (e.g. Na^+ , OH^- , O^{2-}) is also likely to be changed in response to an induced surface potential [61]. Presumably, an excess of positive ions will accumulate near the surface when the adsorbate donates electrons to the glass, and negative ions will accumulate when the glass donates electrons to the adsorbate. In either case, however, the outcome will be an excess of non-network ions in the surficial region and, since such ions weaken glass [62], a decrease in hardness will result.

The hypothesis that adsorption-induced charge carrier redistribution is fundamental to the occurrence of chemomechanical effects appears to be in accord with all phenomenology reported so far. For example, dislocation mobility in ionic solids such as MgO is markedly influenced by dislocation-extrinsic point defect interactions [63], and the state of ionization of these defects will be influenced by the surface potential in some manner specifically dependent upon their type, concentration and initial charge. Consequently, the characteristics of the chemomechanical effects observed for a particular ionic crystal should be dependent upon the concentration and electronic nature of its impurities, as has been demonstrated [64]. On the other hand, for covalent solids such as alumina and certain crystalline silicates, in which dislocation-lattice interactions dominate dislocation mobility, the hypothesis allows for the observed lack of sensitivity of chemomechanical effects to impurity concentrations [57, 59, 60]. In addition, the hypothesis predicts for s.l. glass the observed occurrence of a hardness maximum at the iso-electric point, when there should be no significant chemisorption-induced migration of (softening) non-network ions towards the surface. For a more complete discussion of possible mechanisms, see [58] and [60].

Although surface-active environments do not affect the propagation of fast moving cracks in ceramic solids [51], it seems not unreasonable to

expect that they will influence the propagatability of slowly moving cracks by affecting dislocation mobility in the vicinity of the crack tip [52]. Such an effect could either facilitate sub-critical crack growth by the dislocation emission processes discussed by Clarke *et al.* [65] and others, leading to delayed failure, or result in crack blunting and reduced propagatability. This would be an interesting and possibly important topic for study, being directly relevant to the anticipated future use of ultrahard, notch-brittle solids as structural materials.

Now if, as suggested above, cracks are initiated in a notch-brittle solid soon after the onset of macroscopic flow, then there should be some correlation between the effects of a given environment on the flow behaviour, i.e. dislocation mobility, and on the fracture behaviour of such a material. Such a correlation has been revealed during studies of the environment-sensitive drilling behaviour of MgO and CaF_2 [66]. One direct measure of dislocation mobility (inversely related to flow stress) is the extent to which dislocations move away from a standard microhardness impression in a given time, say 1000 sec, as revealed by etch pitting. In the work of the author and his colleagues, this parameter is referred to as $\Delta L(1000)$ [60, 64, 67] (see Fig. 15 for a more precise definition [67]). Likewise, one indication of the fracture behaviour of a solid, albeit a rather complicated one, is the extent to which a carbide spade bit penetrates the solid under given conditions of thrust, rate of rotation and time. And Fig. 16 indicates that a simple correlation exists between $\Delta L(1000)$ and depth of bit penetration in 600 sec, $D(600)$, for MgO in binary DMF-DMSO (dimethyl sulphoxide) solutions [66]. Specifically, spade bit penetration is greatest for those environments which maximize dislocation mobility and minimize hardness, i.e. presumably give rise to $\zeta \gg$ or $\ll 0$. A similar correlation has also been noted for CaF_2 [66]. Thus a simple relationship exists between environment-sensitive dislocation behaviour and machining efficiency in these ideal cases.

Spade bits blunt quickly in harder and more brittle solids, however, and so are impractical to use. For such solids, various types of diamond-loaded bits are usually employed. In this case, an opposite correlation between hardness and drilling efficiency is found [68], namely, that drilling rate is greatest when hardness is a maximum, i.e. when $\zeta \simeq 0$ [55]. Fig. 17 presents

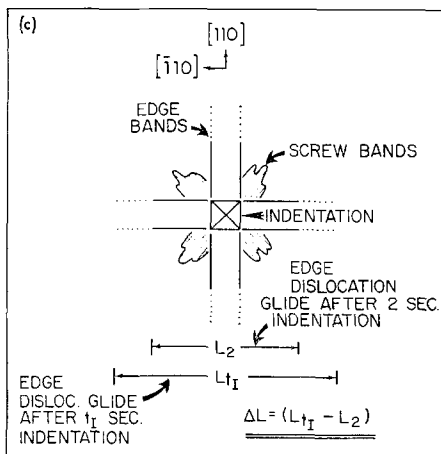
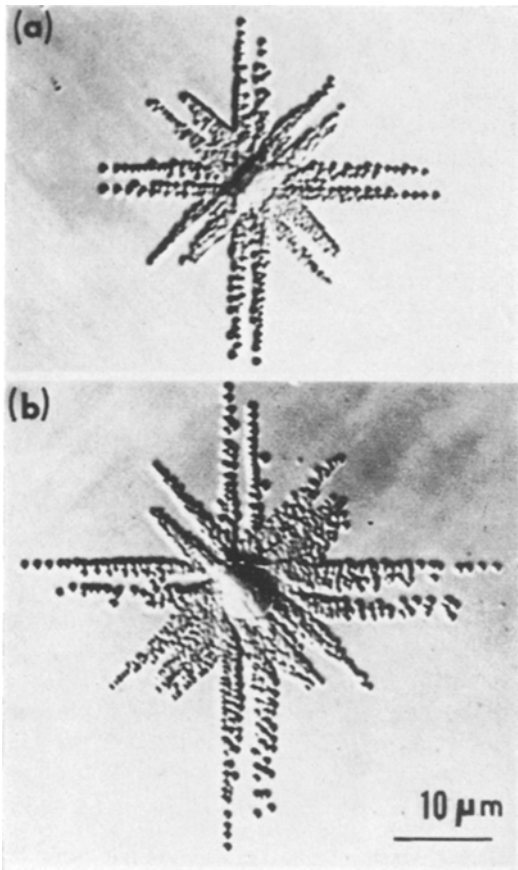

Figure 15 Illustrating dislocation distributions around microindentations in freshly cleaved MgO surfaces after (a) a 2 sec indentation in DMF; (b) a 4000 sec indentation in DMF. 10 g load. (c) Schematic representation of dislocation distribution to define ΔL [67].

an example of such behaviour in alumina [57]. Of especial interest is the significant increase in 1884

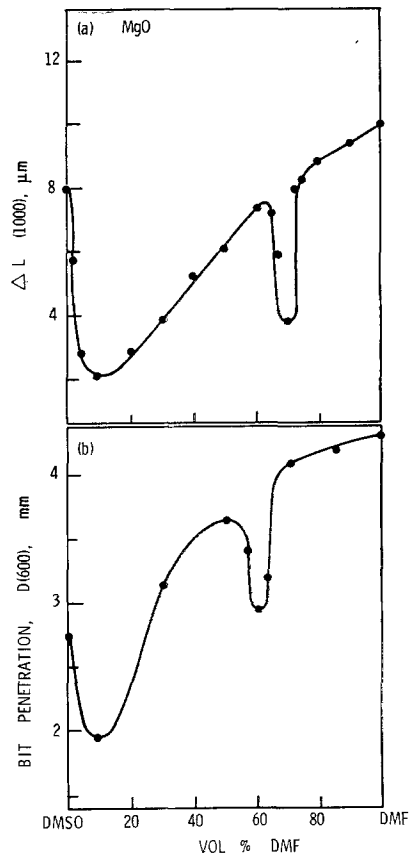

Figure 16 Variation in (a) edge dislocation mobility [64] and (b) penetration by a carbide spade bit in 600 sec [66] for MgO in DMSO-DMF solutions.

penetration rate for those environments for which $\zeta \approx 0$ (pentyl and octyl alcohols) compared to water, for which $\zeta \gg 0$. In the particular data shown, the average rate of penetration after 200 sec, $D(200)$, is eight to ten times greater for these two alcohols than for water.

Another example of the opposite effects of a given environment (water buffered with NaOH or HCl) on the rate of penetration of a given solid (calcite) by carbide spade and diamond-loaded, hemispherical ended bits is shown in Fig. 18c [58]. A comparison of these data with the ζ -potential [69] and pendulum hardness [70] data of Fig. 18a and b, respectively, shows that for calcite the rate of penetration is greatest for the diamond-loaded bit and least for the carbide space bit when $\zeta \approx 0$ and hardness is greatest. Similar behaviour has been observed also when drilling MgO in the *n*-alcohols [68].

That such opposing effects can occur in the

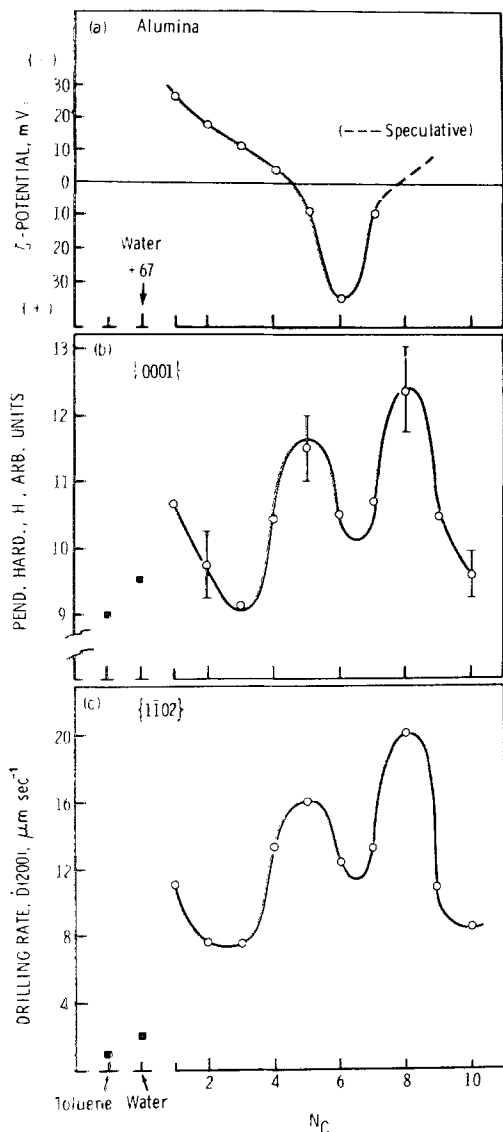

Figure 17 (a) ζ -potential, (b) pendulum hardness and (c) rate of core bit drilling for alumina in toluene, water and n -alcohol environments [57]. N_c is the number of carbon atoms in the alcohol molecule.

same environment, in the presence of the same impurities, and with the same cooling, lubricating and dissolution properties, demonstrates that none of these latter factors exerts the controlling influence on drilling rate, i.e. fracture behaviour. Rather, it is considered that such opposing influences of a specific environment derive from the different roles played by environment-sensitive near-surface flow behaviour in the

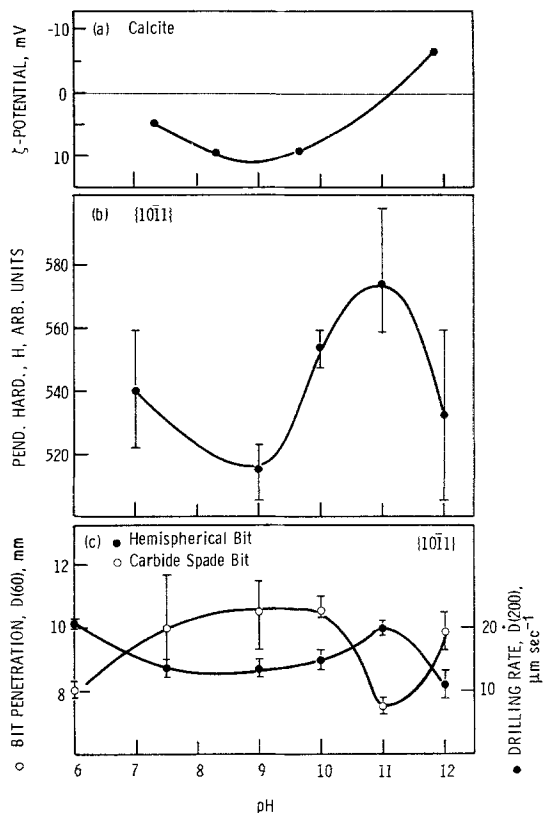

Figure 18 Variation of (a) ζ -potential, (b) pendulum hardness, and (c) penetration by a diamond-studded bit after 200 sec for calcite monocrystals as a function of pH in buffered water environments [58].

formation of chips by different types of bits [58, 68].

For spade bits, it seems reasonable to suppose that a significant amount of plastic deformation necessarily occurs in a "flow-zone" immediately ahead of the cutting edge, in a manner analogous to conventional metal cutting. Since material in this zone cannot readily escape around the edge of the bit, strain accumulates, rapidly exhausting the limited work-hardening capacity of materials such as MgO or calcite. As deformation proceeds, dislocations pile up at slip band intersections and nucleate cracks. These grow quickly to critical size, and then propagate and interact to complete the process of chip formation. According to this view, then, the rate of penetration of a spade bit varies with environment in the same manner as dislocation mobility, because the dislocation motion that comprises the essential first step in the chip formation process is environment-sensitive.

In contrast, the many irregularly shaped diamonds protruding from a core or hemispherical-ended bit may be regarded as individual cutting tools, each having a short curved cutting edge, a large negative rake angle, and travelling in a concentric circular groove. To the extent that environment-sensitive dislocation motion occurs adjacent to such a tool, it is thought to produce an outward, radial flow of material towards the edges of the groove made by the tool, where no further plastic strain can accumulate. Hence, such flow is not envisaged as the primary mechanism of chip formation. Rather, it is postulated that chips are produced mostly by the coalescence of cracks formed immediately behind the tool, where large tensile stresses may be expected in the near-surface region just damaged by passage of the tool. Such plastic flow as does occur is presumed to both lower the level of stress achieved beneath the tool and to blunt the cracks involved in chip formation – two negative influences. For diamond bits, therefore, any environment which facilitates dislocation mobility reduces drilling efficiency. (Similar concepts may be invoked to explain the similar environment-sensitive effects observed in the drilling of s.l. glass (see Section 4.1) given that some different flow mechanism may be involved.)

From the above discussion, it may be concluded that the specific cutting action of the tool, the deformation characteristics of the workpiece, and the influence of the environment on the near-surface flow and fracture behaviour of the workpiece must be considered in toto before any recommendation for chemical optimization of some particular machining operation can be made.

It is only fair to state at this point that the usual reaction to the presentation of data such as that in Fig. 17c is one of scepticism, and questions of reproducibility immediately arise. Nevertheless, extensive testing has revealed that the maxima and minima are quite reproducible for any given type of alumina and testing procedure. And, even more surprising, any particular maximum – say that occurring in pentyl alcohol – can be reproduced by mixing together alcohols from the same homologous series on either side of the alcohol in question. Such behaviour is illustrated in the data of Fig. 19, and similar behaviour has also been observed in drilling studies with glass [68] and granite [59]. Such data establish that the extremum values are real, and not specific to any particular

environment. It follows, also, that such maxima and minima are not related to the presence of impurities in the particular alcohol being used, or to the occurrence of some specific dissolution or lubrication phenomenon in this environment.

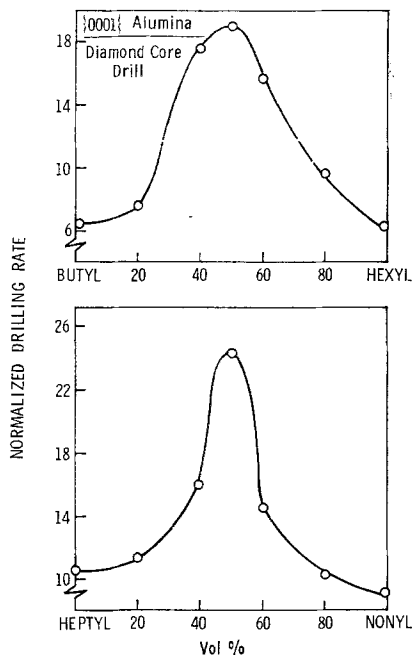

Figure 19 Rate of drilling of alumina monocrystals in binary solutions of *n*-alcohols [57].

The mixed-alcohol effect can be readily understood, however, in terms of the relationship between ζ -potential and hardness. If one component of the binary solution (e.g. hexyl alcohol in Fig. 19a) imparts a positive ζ -potential to the solid, and the other (e.g. butyl alcohol in Fig. 19a) imparts a negative ζ -potential, then some mixture of the two components must give $\zeta \approx 0$, and so produce the appropriate maximum in hardness and diamond bit penetration rate.

This result has extremely useful practical implications for drilling and machining technology. It implies that any liquid which imparts the same ζ -potential to the solid to be drilled will provide essentially the same drilling rate. Thus, a wide choice of cutting fluids are likely to be available for each substance, and it should be possible to find or formulate one that is cost effective as well as non-toxic and non-polluting. Note, however, that a given cutting fluid will normally be optimum only for the particular

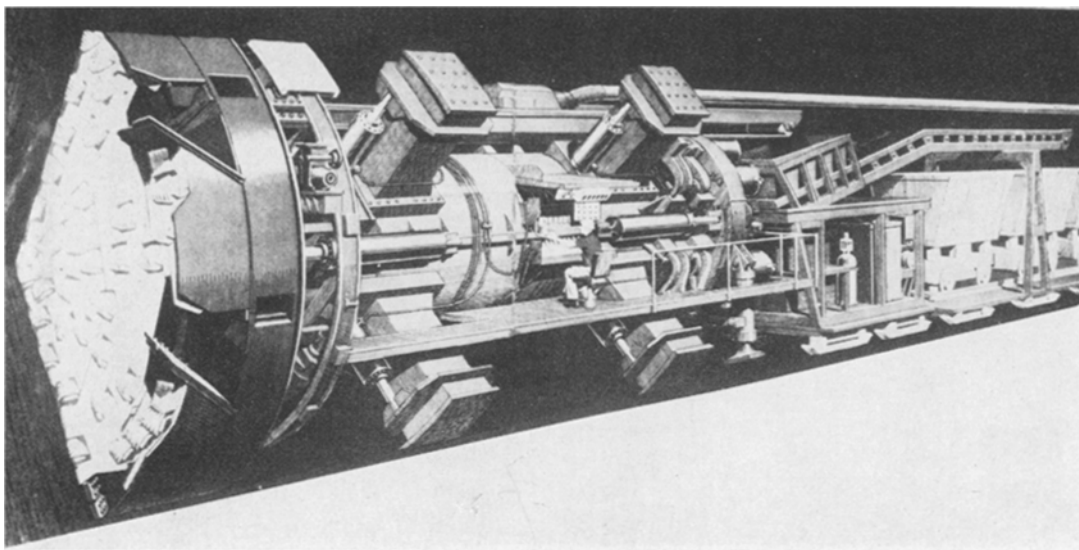

Figure 20 Schematic diagram of mole rock cutter. (Courtesy *Popular Science Magazine*.)

combination of solid and cutting tool for which it was developed. Specifically, any change of tool which alters the mechanism of chip formation will require a different cutting fluid to achieve optimum performance.

3.3. Minerals and rocks

It has been estimated that, during the next decade, some 350 000 km of tunnels will be constructed through hard rock in the 18 OECD* nations, the cost being about \$30 billion [71]. In the US alone, the projected total expenditure for tunnelling in all kinds of rock is \$50 to \$80 billion over the next 20 years [72]. Clearly, therefore, even modest improvements in tunnelling efficiency could result in significant cost savings. The most recent practical advance in this direction has been development of the mechanical mole (Fig. 20). Unfortunately, use of these machines is limited at present to rocks having uniaxial compressive strengths of $< 210 \text{ MN m}^{-2}$ ($< 30 \times 10^3 \text{ psi}$). Harder rocks can be bored for short distances, but the cost of replacing the carbide cutters becomes prohibitive, and conventional drill-and-blast techniques still remain more economical [73]. However, the possibility of using chemo-mechanical phenomena to alter the fracture properties of hard rocks such as granite so as to bring them within a mole's capabilities is of evident interest. With this in mind, therefore, the

*Organization for Economic Cooperation and Development.

concepts discussed in the preceding section have recently been applied to the laboratory-scale rotary diamond drilling of quartz and several types of granite.

Fig. 21 illustrates the variation in pendulum hardness and rate of diamond rotary drilling of quartz monocrystals in water, toluene and the *n*-alcohols [59]. (The corresponding hardness and drilling data for a relatively impure polycrystalline quartz of large (1-2 mm) grain diameter is almost identical.) As before, an excellent correlation between environment-sensitive hardness and drilling rate is evident. And, although the corresponding ζ -potential data are not available, it seems reasonable to assume that the several maxima observed each correspond to an iso-electric point, cf. Fig. 13. Note especially that the rather modest increases in hardness produced ($\sim 30\%$ relative to the hardness in water) are sufficient to allow marked increases in the rate of rotary diamond drilling, in this instance a fourteen-fold increase when undecyl alcohol is the test environment.

Fig. 22 presents comparable data on the rotary drilling of grey granite using diamond core bits ($\sim 6 \text{ mm}$ diameter) [59]. Note the doubling of penetration rate for undecyl alcohol with respect to water. The similarity between these results and those shown in Fig. 21b for monocrystalline quartz is quite striking, and probably implies that the (harder) quartz phase controls the drilling

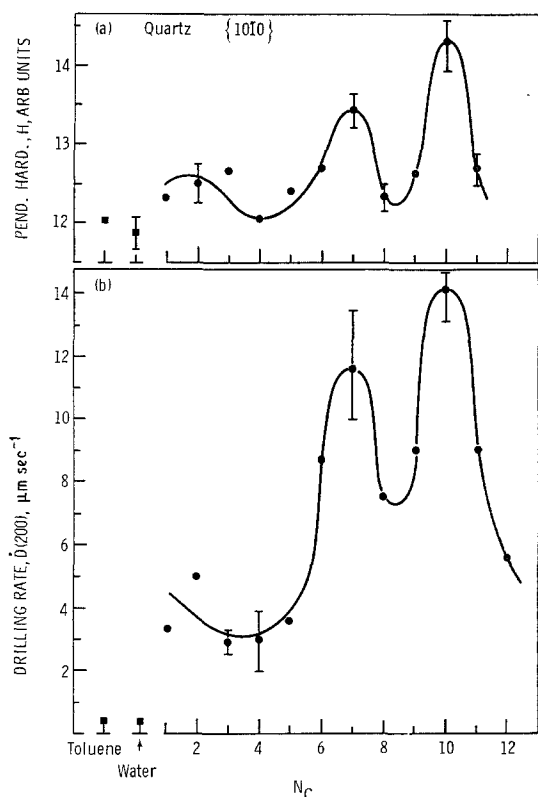

Figure 21 Variation of (a) pendulum hardness and (b) rate of penetration by diamond core bit for quartz monocrystals in toluene, water and *n*-alcohol environments.

behaviour of granite, at least in *n*-alcohol environments.* It also shows that, under the drilling conditions employed, grain boundaries and other microstructural imperfections in the granite play no significant role in the chip formation process.

As with other materials, the drilling rate maxima occurring for quartz and granite in heptyl and undecyl alcohols can be reproduced in appropriate binary alcohol solutions. This is taken to mean that the drilling behaviour of quartz and granite in the *n*-alcohols probably is controlled by its surface charge (ζ -potential).

Unfortunately, the *n*-alcohols are not realistic drilling aids for large scale use, because they are both noxious and costly. Accordingly, the possibility of developing more practical but equally effective cutting fluids is now being vigorously pursued. To illustrate: the negative

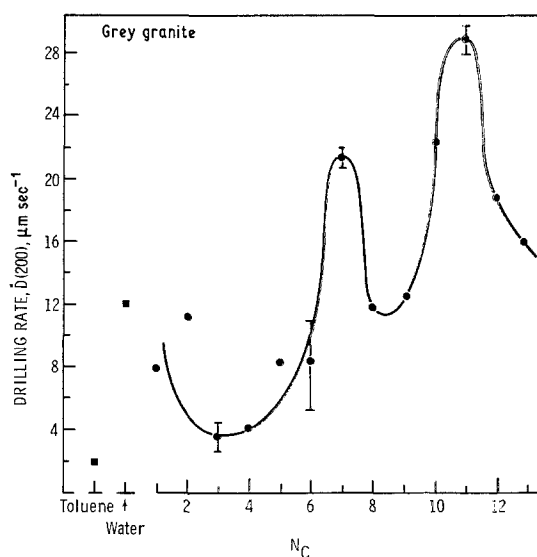

Figure 22 Rate of drilling of grey granite with hemispherical-ended diamond bit in toluene, water and *n*-alcohol environments [59].

ζ -potential exhibited by most silicates in water can be increased to zero by addition to the water of appropriate concentrations of various surface-active species. For quartz and Westerly granite, in particular, recent streaming potential studies [74] reveal that the addition of 10^{-3} to 10^{-4} moles l^{-1} of the cationic flotation agent DTAB (dodecyl trimethyl ammonium bromide) produces the desired result (Fig. 23). Thus, aqueous DTAB solutions might be expected to significantly influence the rotary diamond drilling of these materials. The data shown in Fig. 24 confirm this conjecture for core bits rotating at 2200 rpm. Note that both quartz and granite show a qualitatively similar variation of drilling rate with DTAB concentration, with maxima at some concentration close to that corresponding to the iso-electric point. Thus, the harder quartz phase controls the rotary diamond drilling behaviour of granite in aqueous DTAB environments as well as in the *n*-alcohols. Note, also, the eight-fold increase in drilling rate in 10^{-3} molar DTAB over that in water. Other work [59] indicates that up to three-fold improvements can be obtained when the thrusts and rates of bit rotation are adjusted to provide penetration rates similar to those currently used in mole operations in hard rock, i.e. $\sim 10^{-4}$ m sec^{-1} (~ 1 ft h^{-1}).

*Other data shows that the feldspar phase in granite exhibits a characteristically different variation of $\dot{D}(200)$ with N_c [59].

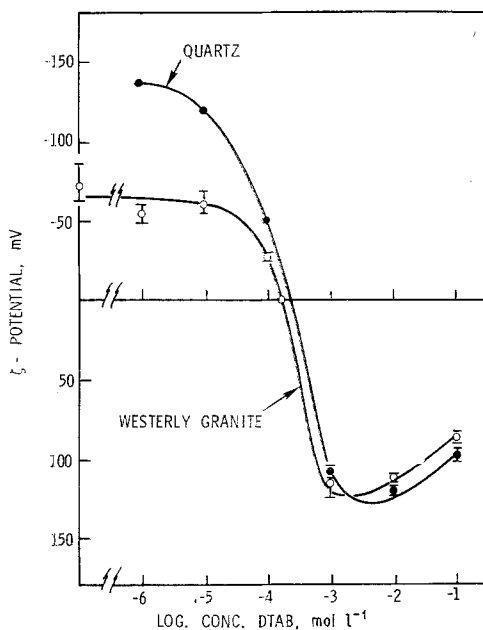

Figure 23 Variation in ζ -potential of quartz and Westerly granite as function of concentration of DTAB in water [74].

Bearing in mind that increasing the overall rate of cutter advance by only 25% could result in an 8% reduction in tunnelling costs [75], these developments are quite exciting.

Finally, work in progress [76] also confirms Rebinder's [5] observation that significant increases in the rates of penetration of impact bits (as contrasted to rotary bits) also can be achieved by chemical means.

4. ESFP in non-crystalline and organic materials

4.1. Silica glasses

The fracture behaviour of a silica glass can be markedly influenced by its testing environment, and both crack initiation [77] and crack propagation [78] processes can be affected. Explanations for the technologically important manifestation of such effects, namely delayed failure (static fatigue), usually fall into one of two categories, (i) those dependent upon adsorption-induced reductions in surface free energy, and (ii) those which assume the presence of water to be critical, and of which the stress-enhanced corrosion mechanism of Charles and Hillig [79] is perhaps most widely accepted. For explanations in category (ii), the role of

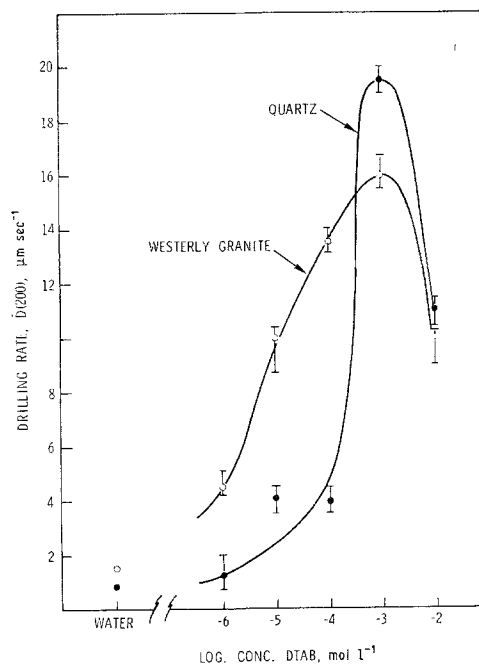

Figure 24 Rate of drilling of quartz monocrystals and Westerly granite as a function of concentration of aq. DTAB environments [74].

testing media other than water is usually considered to be simply that of screening the highly reactive water molecules from the glass surface.

However, there is much evidence that, under conditions where fracture is induced by abrasion, grinding or drilling, certain organic environments are considerably *more* active than water. For such examples of environment-sensitive fracture behaviour it would certainly appear that explanations dependent upon the dominant presence and corrosive influence of water could not be relevant.

An interesting recent development in this regard is the observation of what appears to be adsorption-controlled, flow-facilitated, slow crack growth in soda lime glass when stressed in non-corrosive environments (Fig. 25) [61]. Of course, it has been suggested previously that localized plastic flow can occur in the vicinity of crack tips in soda-lime glass [80, 81]. However, in these earlier considerations, flow was not thought of as a means of *facilitating* crack growth.

The data shown in Fig. 25 were obtained using the centre-loaded crack technique illustrated in

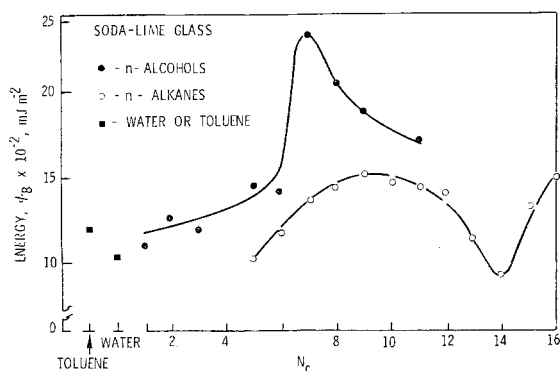

Figure 25 Influence of environment on energy (ϕ_B) to propagate a stable crack in a semi-brittle manner in soda-lime glass [61].

Fig. 26 [82]. The specific advantage of this technique is that, within the dimensional restrictions shown in the figure, the load required to propagate the crack increases with crack length (the converse of the "Griffith-crack" situation). The crack thus extends in a stable manner at a velocity dependent upon its length and the rate of loading. The energy, ϕ_B , required to propagate centre-loaded cracks in a stable mode is calculated from the relationship [83]

$$\phi_B = P^2(1 - \nu^2)/2c\pi Eh^2,$$

in which P is the instantaneous load to continue slow propagation of a crack of length $2c$, ν is Poisson's ratio (0.22), E is Young's modulus (71.8 GN m^{-2}), and h is the thickness of the glass sheet.

Note particularly the maximum in ϕ_B which occurs in heptyl alcohol. Other work [61] reveals that this maximum can be reproduced by solutions of octyl alcohol in pentyl alcohol. Likewise, the maximum (at $N_C \approx 10$) and minimum (at $N_C \approx 14$) in the ϕ_B versus N_C (alkanes) plot can be reproduced by, respectively, solutions of tetradecane in pentane and pentadecane in undecane.

Clearly, such behaviour is unlikely to be related to any corrosion phenomenon because most of the environments used were, as far as can be ascertained, non-corrosive with respect to glass, and in any event the effects of binary solutions are inconsistent with such a possibility. Nor can such behaviour be rationalized in terms of adsorption-induced reductions in the brittle fracture energy of glass for, if this were so, then ϕ_B should be a minimum in heptyl alcohol

because, as will be shown below, this environment maximizes the hardness of soda-lime glass, and so would be expected to facilitate its failure by brittle processes.

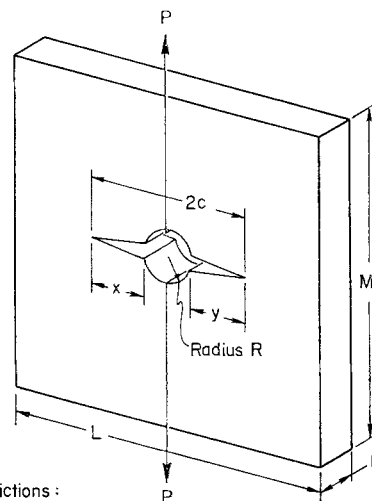

- Restrictions:
- $2c < 0.25L$
 - $x = y > R$
 - $M \approx L$

Figure 26 Schematic of specimens used in studies of environment sensitive slow crack growth in glass [61].

It has been suggested [61], therefore, that ϕ_B should be regarded *not* as a measure of the true surface energy of glass, but rather as a relative measure of the energy required to propagate a sub-critical crack in a semi-brittle manner at a rate dictated primarily by the rate of loading. The data can then be interpreted as follows: non-corrosive environments which, by adsorption, soften soda-lime glass (e.g. ethyl alcohol or tetradecane), facilitate slow crack growth by localized flow processes. Therefore, the external load (P) required to maintain crack propagation at a particular rate is reduced, and ϕ_B , which is proportional to P^2 , is then relatively low. Environments which maximize the hardness of glass, on the other hand (e.g. heptyl alcohol), minimize flow-assisted crack growth, and in such cases ϕ_B is relatively high.

Work in progress indicates that the environment-dependent surface charge plays an important role in determining sub-critical crack growth behaviour in glass [84]. For example, an environment which produces $\zeta \geq 0$ softens soda-lime (s.l.) glass (Fig. 27a and b) [55], and such an

effect occurring in the vicinity of a stressed crack tip can be either beneficial or detrimental to crack growth depending on crack velocity, fracture mode, etc. On the other hand, an environment such as heptyl alcohol which produces $\zeta \approx 0$ on s.l. glass maximizes its hardness (Fig. 27b), and minimizes the influence of localized stress relaxation processes on crack propagation behaviour. Presumably, water is a severely detrimental environment for s.l. glass because it combines all three important influences of an environment – it reduces its surface free energy, causes stress-enhanced corrosion and, by virtue of the large ζ -potential associated with its adsorption (~ -140 mV), induces flow-facilitated subcritical crack growth.

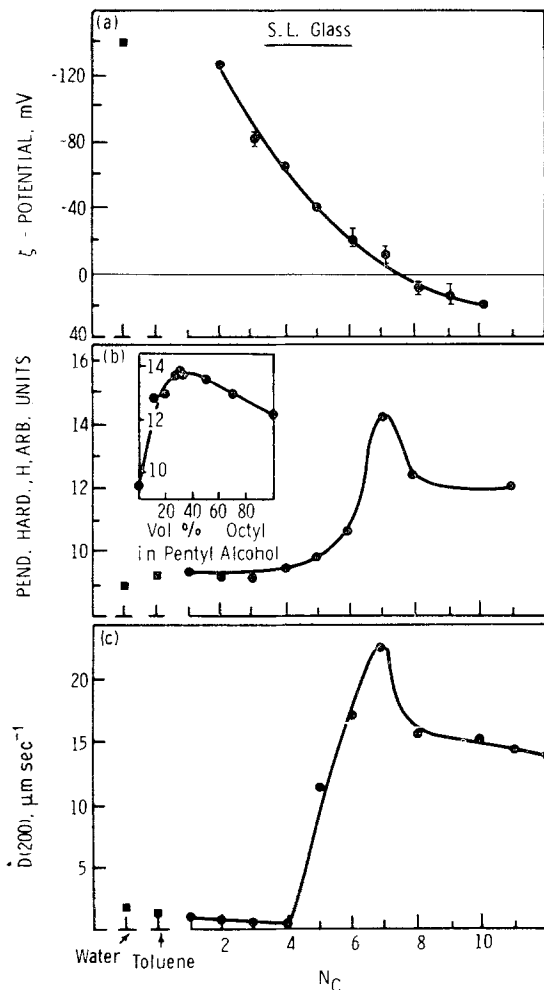

Figure 27 Variation in (a) ζ -potential, (b) pendulum hardness and (c) rate of penetration with a diamond-studded bit of s.l. glass [68] in toluene, water and *n*-alcohol environments [58].

Such environmentally-induced changes in the hardness of s.l. glass can have a profound influence on its machining behaviour. The data of Fig. 27c [68] show, for example, that under otherwise identical testing conditions, a conventional window glass can be drilled ten to twenty times faster by a diamond-loaded bit in heptyl alcohol than in water. Comparable increases also can be obtained in $\sim 10^{-3}$ M aqueous solutions of DTAB, which also produce $\zeta \approx 0$. Appropriately formulated fluids also can increase the rate of grinding of glass by factors of two or three over that obtained in pure water [76], a finding which should be of interest to the extremely labour-intensive optics industry.

The fact that a “ ζ -correlation” occurs for both crystalline and non-crystalline inorganic non-metals is of great interest, and implies the possibility of certain commonalities of mechanism. In view of the lack of long-range order in glasses, however, it is presumably at the atomic scale that any commonalities of mechanism must be sought. With this in mind, it has been conjectured [60] that the similarities in the environment-sensitive mechanical behaviour of crystals and glasses may arise because of the similar influence of chemisorption-induced changes in near-surface electronic structure on the fundamental unit of plastic flow, namely the formation and/or unit motion of kinks along near-surface dislocations in crystals or “dislocation-like” defects in glasses.

4.2. Organic crystals and polymers

Examples illustrative of the control or application of environment-sensitive fracture behaviour in organic crystals or polymers are not easy to find. Conversely, the detrimental influences of certain environments on the strength and reliability of such solids are well known [85]. By way of example, Pertsov and Sinevich *et al.* (cited in [18]) have demonstrated that molecular organic crystals, such as naphthalene and anthracene, are especially vulnerable to non-polar fluids. For example, under ordinary conditions, naphthalene is very ductile. Yet, in the presence of benzene or heptane (presaturated with naphthalene), it is brittle and fails by cleavage after only a few percent strain. Its behaviour is very reminiscent of that of the zinc-liquid mercury embrittlement couple.

Skvortsov *et al.* [86] have determined the energy, γ , to propagate a cleavage crack in naphthalene in a variety of environments, e.g.

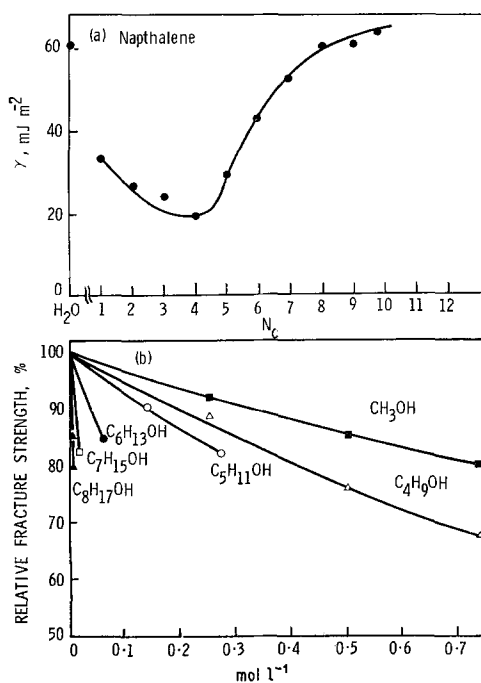

Figure 28 (a) Cleavage surface energy, γ , of naphthalene in water and the n -alcohols [86]. (b) Relative strength of polycrystalline naphthalene in aqueous solutions of the n -alcohols as function of concentration [87].

Fig. 28a. In air and water – apparently inert media – γ is identical and a maximum of $\sim 60 \text{ mJ m}^{-2}$ ($\equiv \text{erg cm}^{-2}$).^{*} In benzene, $\gamma \approx 10 \text{ mJ m}^{-2}$. In the n -alcohols, γ is reduced to $\sim 20 \text{ mJ m}^{-2}$ at $N_C = 4$ (butyl alcohol), but then returns to $\sim 60 \text{ mJ m}^{-2}$ at $N_C = 8$ (octyl alcohol). This increase is considered to arise because the molecular size of the higher alcohols prevents them from reaching the crack tip. There is some question about the validity of this explanation, however, because dilute solutions of octyl alcohol in water produce marked embrittlement of polycrystalline naphthalene (Fig. 28b) [87], and it is difficult to see why two substances which separately do not reduce γ (i.e. water and octyl alcohol, Fig. 28a) together should do so. An alternative and rather speculative possibility is that the isoelectric point ($\zeta \approx 0$) for naphthalene in the n -alcohols occurs in butyl alcohol, and so this normally ductile solid is hardest and most easily cleaved in this environment (i.e. γ is a minimum). However, an equivalent iso-electric point can be produced by mixing together in

some proportion two liquids which, individually, produce larger values of the ζ -potential, but which are of opposite sign. Hence the embrittlement in water-octyl alcohol solutions. It would be of interest to determine whether dilute solutions of octyl alcohol in water reduce γ to the value obtained in pure butyl alcohol, that is, $\sim 20 \text{ mJ m}^{-2}$. If so, the steric hindrance hypothesis would be invalidated.

The deleterious influence of certain polar liquids on the durability of polymers such as polyethylene (PE) has been a matter of record for almost thirty years [88], and the premature failure of plastic tubing following extended contact with oils and fuels is well known. Recent work in the USSR [10] has been directed towards understanding the selective influence of various media on fracture behaviour, and some interesting patterns of behaviour are beginning to emerge. The fracture strength, σ_F , of polyethylene, for example, is reduced as the polarity of the medium is reduced. Thus, σ_F decreased by $\sim 10\%$ in methyl alcohol, 40% in hexyl alcohol (Fig. 29) and 50 to 60% in certain hydrocarbons, relative to σ_F in air.

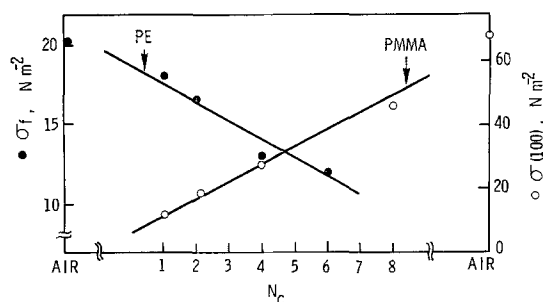

Figure 29 Effect of n -alcohols on (a) fracture strength, σ_F , of polyethylene (PE), and (b) stress to cause failure in 100 sec, $\sigma(100)$, of polymethylmethacrylate (PMMA) [10].

For polymethylmethacrylate (PMMA), on the other hand, the trend is in the opposite direction (Fig. 29). In this instance, the stress to cause failure of a precracked specimen in 100 sec, $\sigma(100)$, is some six times less in methyl alcohol than in air, but only one third less in octyl alcohol. Although such trends are not too reliable [18], an awareness of them at least provides an opportunity to minimize the risk of premature failure in a given environment by

^{*}A subsequent analysis of the experimental technique adopted by Skvorstov *et al.* indicates that the values of γ derived by these workers, and shown in Fig. 28a, are low by factors of 1.5 to 3 times [89].

choosing an appropriately resistant type of polymer.

5. Conclusion

Chemically active environments can influence fracture processes in all types of solids. And our ability to minimize their usually detrimental influences on component reliability, and capitalize on their sometimes beneficial influences on materials removal processes, is likely to be related directly to our level of mechanistic or conceptual understanding of such effects. At present, such understanding is extremely limited. In part, this is a consequence of our inadequate comprehension of some of the fundamental processes involved, e.g. of the specific electronic interactions which occur between adsorbates and adsorbents during chemisorption, and of the influence, if any, of lattice strain on such interactions. Perhaps the greater obstacle to immediate progress, however, is the interdisciplinary nature of this field of study, involving as it does the complicated interplay of variables arising from the chemistry of the environment, the physics of the near-surface layers of the solid, and the materials science and engineering of the bulk. Improved dialogue between workers in these fields would be most valuable. In short, the field of environment-sensitive fracture behaviour is likely to present an exciting challenge to research scientists and a golden opportunity for development engineers for some time to come.

Acknowledgements

It is a pleasure to acknowledge the generous assistance received from colleagues H. W. Hayden, M. V. Swain, and especially J. A. S. Green, R. D. Huntington, R. M. Latanision and C. Joyce Kidwell, during the preparation of this review.

References

- O. REYNOLDS, *Manchester Lit. Phil. Soc.* **13** (1874) 93.
- J. C. SCULLY, "Theory of Stress Corrosion Cracking of Alloys", (NATO, Brussels, 1971).
- A. M. JOFFE, M. W. KIRPITSHEVA and M. A. LEWINSKY, *Z. Physik*, **22** (1924) 286.
- A. R. C. WESTWOOD, *Ind. and Eng. Chem.* **56** (1965) 14.
- P. A. REBINDER, L. A. SCHREINER and S. F. ZHIGACH, "Hardness Reducers in Rock Drilling" (Academy of Science, USSR, Moscow, 1944) C.S.I.R.O. (translation, Melbourne, 1948).
- Photograph courtesy of E. J. KING, Bell Aero-systems, Textron Co., Buffalo, N.Y.
- A. R. C. WESTWOOD, C. M. PREECE and M. H. KAMDAR, *Trans. ASM* **60** (1967) 723.
- A. R. C. WESTWOOD, D. L. GOLDHEIM and E. N. PUGH, *Acta Met.* **13** (1965) 695.
- N. V. PERTSOV, E. A. SINEVICH and E. D. SHCHUKIN, *Dokl. Akad. Nauk. SSSR* **179** (1968) 633.
- E. D. SHCHUKIN, A. I. SOSHKO, O. A. MIKITYUK and A. N. TYNNYI, *Sov. Mat. Sci.* **7** (1973) 160.
- S. M. WIEDERHORN, *J. Amer. Ceram. Soc.* **50** (1967) 407.
- A. R. C. WESTWOOD and R. M. LATANISION, "Corrosion by Liquid Metals" (Plenum, New York, 1970) p. 405.
- A. R. C. WESTWOOD, C. M. PREECE and M. H. KAMDAR, "Fracture", Vol. 3 (Academic Press, New York, 1971) p. 589.
- W. ROSTOKER, J. M. MCCAUGHEY and H. MARKUS, "Embrittlement by Liquid Metals" (Reinhold, New York, 1960).
- V. I. LIKHTMAN, E. D. SHCHUKIN and P. A. REBINDER, "Physico-chemical Mechanics of Metals" (Academy of Science, USSR, Moscow, 1962).
- M. HANSEN, "Constitution of Binary Alloys" (McGraw-Hill, New York, 1958).
- A. R. C. WESTWOOD, "Strengthening Mechanisms - Metals and Ceramics" (Syracuse Univ. Press, Syracuse, 1966) p. 407.
- Cited in P. A. REBINDER and E. D. SHCHUKIN, *Prog. Surface Sci.* **3** (1972) 97.
- C. M. PREECE and A. R. C. WESTWOOD, *Trans. ASM* **62** (1969) 418.
- Idem*, "Corrosion by Liquid Metals" (Plenum, New York, 1970) p. 441.
- S. MOSTOVEY and N. N. BREYER, *Trans. ASM* **61** (1968) 219.
- E. D. SHCHUKIN, Z. M. POLUKAROVA, V. S. YUSHCHENKO, L. S. BRUYUKHANOVA and P. A. REBINDER, *Sov. Phys. Doklady* **17** (1973) 699.
- A. V. PERTSOV, U. V. GORYUNOV, N. V. PERTSOV, E. D. SHCHUKIN and P. A. REBINDER, *Dokl. Akad. Nauk. SSSR* **172** (1967) 1137.
- M. V. HYATT and M. O. SPEIDEL, in "Stress Corrosion Cracking in High Strength Steels and in Aluminum and Titanium Alloys" (edited by B. F. Brown) (US Government Printing Office, Washington, D.C., 1972) p. 147.
- B. F. BROWN (ed.), "Stress Corrosion Cracking in High Strength Steels and in Aluminium and Titanium Alloys" (US Government Printing Office, Washington, D.C., 1972).
- J. A. S. GREEN and H. W. HAYDEN, "Hydrogen in Metals" (edited by J. M. Bernstein and A. W. Thompson) (Amer. Soc. Metals, Cleveland, 1973), p. 235.

27. J. A. S. GREEN and W. G. MONTAGUE, Martin Marietta Labs, unpublished work, January 1974.
28. S. FLOREEN, H. W. HAYDEN and N. KENYON, *Corrosion* **27** (1971) 519.
29. B. W. LIFKA and D. O. SPROWLS, Paper presented at 26th Annual Conference of N.A.C.E., Philadelphia, Pa., March 1970.
30. G. SANDOZ, in "Stress Corrosion Cracking in High Strength Steels and in Aluminum and Titanium Alloys" (edited by B. F. Brown) (US Government Printing Office, Washington, D.C., 1972) p. 79.
31. A. J. SEDRIKS, J. A. S. GREEN and D. L. NOVAK, Proceedings of the 5th International Congress on Corrosion, Tokyo, 1972, to be published.
32. B. F. BROWN, C. T. FUJUI and E. P. DAHLBERG, *J. Electrochem. Soc.* **116** (1969) 218.
33. K. G. KENT, *J. Inst. Met.* **97** (1969) 127.
34. R. E. CURTIS and P. T. FINDEN, Boeing Document D6-22997-1, The Boeing Company, Seattle, Washington, July 1969.
35. A. J. SEDRIKS and J. A. S. GREEN, *J. Metals* **23** (1971) 48.
36. R. M. LATANISION, K. C. NIELSEN and R. KIRSCHBAUM, *Modern Machine Shop*, February 1974.
37. J. O'M. BOCKRIS, S. D. ARGADE and E. GILEADI, *Electrochim. Acta* **14** (1969) 1259.
38. A. PFUTZENREUTER and G. MASING, *Z. Metall.* **42** (1951) 361.
39. I. R. KRAMER, *Trans. Met. Soc. AIME* **227** (1963) 1003.
40. V. I. LIKHTMAN, L. A. KOCHANOVA, D. I. LEYKAS and E. D. SHCHUKIN, *Electrokhimiya* **5** (1969) 729.
41. R. M. LATANISION and R. W. STAEBLE, *Acta Met.* **17** (1969) 307.
42. R. M. LATANISION, H. OPPERHAUSER and A. R. C. WESTWOOD, "Science of Hardness Testing" (ASM, Metals Park, Ohio, 1973) p. 432.
43. R. M. LATANISION and H. OPPERHAUSER, *Met. Trans.* **5** (1974) 483.
44. R. M. LATANISION and K. C. NIELSEN, Martin Marietta Labs, unpublished work, 1973.
45. W. H. BRATTAIN, "Surface Chemistry of Metals and Semiconductors" (Wiley, New York, 1959) p. 90.
46. F. F. VOLKENSTEIN, "Electronic Theory of Catalysis on Semi-Conductors" (Pergamon, Oxford, 1963).
47. A. R. C. WESTWOOD, D. L. GOLDHEIM and E. N. PUGH, "Grain Boundaries and Surfaces in Ceramics" (Plenum, New York, 1966) p. 553.
48. *Idem*, *Phil. Mag.* **15** (1967) 105.
49. E. N. PUGH and A. R. C. WESTWOOD, "Stress Corrosion Testing", ASTM STP425 (1967) p. 228.
50. A. R. C. WESTWOOD, "Environment-Sensitive Mechanical Behavior" (Gordon and Breach, New York, 1966) p. 1.
51. D. A. SHOCKEY and G. W. GROVES, *J. Amer. Ceram. Soc.* **52** (1969) 82.
52. A. R. C. WESTWOOD and R. M. LATANISION, Proceedings of the ARPA Materials Summer Conference, Woods Hole, Mass. (1972) Vol. 2, p. 62.
53. P. A. REBINDER, private communication, Moscow, 1969.
54. P. SENNETT and J. P. OLIVER, "Chemistry and Physics of Interfaces" (Am. Chem. Soc., Washington D.C., 1965) p. 75.
55. A. R. C. WESTWOOD and N. H. MACMILLAN, "Science of Hardness Testing" (ASM, Metals Park, Ohio, 1973) p. 377.
56. R. W. HEINS and N. STREET, *Soc. Pet. Eng. J.* **5** (1965) 177.
57. A. R. C. WESTWOOD, N. H. MACMILLAN and R. S. KALYONCU, *J. Amer. Ceram. Soc.* **56** (1973) 258.
58. N. H. MACMILLAN and A. R. C. WESTWOOD, "Surfaces and Interfaces of Glass and Ceramics" (Plenum, New York, 1974) in press.
59. A. R. C. WESTWOOD, N. H. MACMILLAN and R. S. KALYONCU, *Trans. AIME (Mining)* **256** (1974) 106.
60. N. H. MACMILLAN, R. D. HUNTINGTON and A. R. C. WESTWOOD, *Phil. Mag.* **28** (1973) 923.
61. A. R. C. WESTWOOD and R. D. HUNTINGTON, "Mechanical Behavior of Materials" (Soc. Matls. Sci., Japan, Tokyo, 1972) Vol. 4, p. 383.
62. S. M. COX, *Phys. Chem. Glasses* **10** (1969) 226.
63. B. J. WICKS and M. H. LEWIS, *Phys. Stat. Sol.* **6** (1971) 281.
64. A. R. C. WESTWOOD, D. L. GOLDHEIM and R. G. LYE, *Phil. Mag.* **17** (1968) 951.
65. F. J. P. CLARKE, R. A. J. SAMBELL and H. G. TATTERSALL, *Phil. Mag.* **7** (1962) 393.
66. A. R. C. WESTWOOD and D. L. GOLDHEIM, *J. Amer. Ceram. Soc.* **53** (1970) 142.
67. A. R. C. WESTWOOD, D. L. GOLDHEIM and R. G. LYE, *Phil. Mag.* **16** (1967) 505.
68. A. R. C. WESTWOOD and R. M. LATANISION, "Science of Ceramic Machining and Finishing" (Nat. Bureau of Standards, Washington, D.C., 1972, SP 348, p. 141.
69. P. SOMASUNDARAN and G. E. AGAR, *J. Coll. and Interface Sci.* **24** (1967) 433.
70. A. R. C. WESTWOOD and N. H. MACMILLAN, Rept. to U.S.G.S. on Contract No. 14-08-0001-13077, Martin Marietta Labs, January 1973.
71. M. P. FLOUVIEZ, Proceedings of the Advisory Conference on Tunneling, O.E.C.D., Washington, D.C., 1970.
72. W. N. LUCKE, Paper presented at the Symposium on the Underground Environment, Geol. Soc. of America, Washington, D.C., 1971.
73. W. E. BRUCE and R. J. MORRELL, "Deep Tunnels in Hard Rock" (U.S.E.P.A., Washington, D.C., 1970) p. 187.
74. N. H. MACMILLAN, R. E. JACKSON and A. R. C. WESTWOOD, Proceedings of the 15th IRSM

- Symposium on Rock Mechanics, September 1973, in press.
75. Quoted in *Mosaic*, a publication of the National Science Foundation, Washington, D.C., Fall 1973, p. 11.
76. R. E. JACKSON, N. H. MACMILLAN and A. R. C. WESTWOOD, Proceedings of the Third IRSM Conference, Denver, Colorado, September, 1974.
77. I. I. KITAIGORODSKI and L. N. KOPYTOV, *Sov. Phys. Doklady* **8** (1963) 308.
78. W. P. BERDENNIKOV, *Zhur. Fiz. Khim.* **5** (1934) 358.
79. R. J. CHARLES and W. B. HILLIG, Symposium on Mechanical Strength of Glass and Ways of Improving It. (Union Scientifique du Verre, Charleroi, 1962) p. 511.
80. D. M. MARSH, *Proc. Roy. Soc.* **A279** (1964) 420.
81. K. R. LINGER and D. G. HOLLOWAY, *Phil. Mag.* **18** (1968) 1269.
82. V. V. PANASYUK and S. E. KOVCHIK, *Sov. Phys. Doklady* **7** (1963) 835.
83. G. I. BARENBLATT, *Adv. Appl. Mech.* **7** (1962) 55.
84. W. M. MULARIE and A. R. C. WESTWOOD, Report to ONR on Contract No. 00014-70-C-0330, Martin Marietta Labs, January 1974.
85. R. P. KAMBOUR, *J. Polymer Sci.: Macromolecular Reviews* **7** (1973) 1.
86. A. G. SKVORTSOV, E. A. SINEVICH, N. V. PERTSOV, E. D. SHCHUKIN and P. A. REBINDER, *Sov. Phys. Doklady* **15** (1971) 669.
87. E. A. SINEVICH, N. V. PERTSOV and E. D. SHCHUKIN, *Dokl. Akad. Nauk SSSR* **197** (1971) 1376.
88. R. B. RICHARDS, *Trans. Faraday Soc.* **42** (1946) 10.
89. D. MAUGIS and G. ANDARELLI, *J. Appl. Phys.* **43** (1972) 4258.

Received 27 March and accepted 21 May 1974.